



## Toys for Tots

Lots of Toys for Tots! Santa's elves have been busy getting toys for many children in the Brown County Area. The toys are on display at the Groton American Legion. Last report, the elves spent over \$12,000 for toys, which will be distributed to many children. (Courtesy photo)



**Living Christmas Tree Groton area performers are pictured L-R -Bev Sombke, Deb Olson, Lee Schinkel, Eric Ulvog (string bass,) Bill Duncan, Sage Mortenson, and Yvonne Lorenz. Front L-R - Valerie Baker, and Vivian Dobberpuhl. Missing from picture were Lon Gellhaus, Seth Duncan, and Marsha Wienk, choir, and Angel Lorenz, orchestra.**

## Doug Sombke Elected to Serve Sixth Term as South Dakota Farmers Union

HURON, S.D. - Doug Sombke was elected by the members of South Dakota Farmers Union to serve a sixth term during the organization's centennial convention held in Huron Dec. 9 and 10, 2015.

"I feel truly honored to serve the membership of this great organization - these are South Dakota's farmers, ranchers and rural citizens," explained Sombke, a fourth generation Conde crop and cattle farmer who has served as the organization's President since 2005.

Serving more than 17,000 family farmers, ranchers & rural citizens statewide as president of one of South Dakota's largest agriculture organizations, Sombke spends his days traveling across the state and nation advocating for family farms, ranches and rural communities, while his three now-grown sons manage the day-to-day farming operations of the family farm. All three sons also operate independent businesses which helps the farm sustain four families.

"It's the next generation of young farmers and ranchers who inspire me - our state's economic future rests in their hands because agriculture is our number one industry. They are the reason I put my all into this role each and every day," Sombke explains. "When I was first asked to serve as President 10 years ago, the timing could not have been better. My sons were ready to become more active on the farm."

Since becoming President 10 years ago, the organizations' membership numbers have soared, reaching a 20-year high of 17,000 in 2015.

"Membership numbers increased in nearly every county throughout South Dakota - this is a clear sign that our organization is not only strong, but growing," says Karla Hofhenke, S.D. Farmers Union Executive Secretary.

Hofhenke that as a grassroots organization, she and the rest of the state staff are led by Sombke and a board of agriculture producers. During state convention, three board members were also reelected. These members include; Wayne Soren, SDFU Vice President, Lake Preston; Jim Wahl, Salem; Lynn Frey, Lemmon; and Joel Keierleber, Colome.



**Midwest Masonry & Concrete Pumping**  
**Greg Heilman, owner**  
 405 E 1st Ave., Groton  
 Greg: 253/929-9137  
 Mike: 605/492-7041  
 midwestmasonry1@yahoo.com



**Kristi Peterson Bookkeeping**  
 Simple Solutions for YOU  
 605/216-4474 ~ peterson4@nvc.net

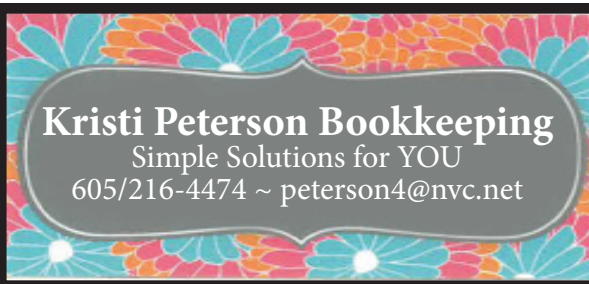

Put our experienced team to work for you!

**GROTON**  
 GROTONFORD.COM 605-397-2311



**ACKIVER COLLISION**  
 Lifetime Warranty on all Collision Work!  
 13556 400th Ave., Groton SD 57445  
 Allen McKiver, Owner ~ 605/397-4404



**JOHNSON AGENCY**  
 Real Estate & Insurance  
**Jay Johnson, Broker**  
 www.johnsonagencygroton.com  
 102 N Main St. Office: 605/397-2424  
 Groton, SD 57445 Home: 605/397-8565



**Dakota Outdoors**  
**Erik Dean**  
 402 N Main St  
 Aberdeen, SD 57401  
 605.229.0123  
 dakoutdoors@midconetwork.com



**HARR Motors**  
 www.harrmotors.com  
 605-225-3078 ~ 1-800-658-3463





**SCHULTZ CONSTRUCTION LLC**  
 CARPENTRY • CONCRETE  
 • BATH, SD •  
 Check out our portfolio on Facebook at **Schultz-Construction-LLC**  
 ~ New Construction and Remodeling- renovations, additions, and carpentry work  
 ~ Concrete- foundations, flatwork, decorative concrete surfaces.  
 605-380-1717  
 www.shawnschultzconstruction.com



**Sperry Stump Removal** Tyler: 605/216-8431  
 Over 30 Years of Combined Experience!  
 TJ: 605/380-7915 **TreeLine Tree Service**



Fresh flowers, silks, home decor  
**Olde Bank Floral**  
 Olde Bank @ Floral  
 & so much more  
 101 N. Main St., Groton ~ 397-8650  
 www.oldebankfloral.com

**Harry Implement**  
 "Family Owned & Operated Since 1935!"  
 CERTIFIED DEALER  
 AFS  
 (605) 395-6421  
 Ferney



**FROST CONSTRUCTION INC.**  
 GENERAL CONTRACTOR  
 605.290.1535  
 custom homes | remodels | additions



## Pray, Anderson win at Lamoure Tourney

Two Groton Area wrestlers went to the Lamoure Wrestling Tournament on Saturday and both came home as champions. "It was another great day for the Groton wrestlers at the Lamoure tournament this past weekend," said Coach Dana Dargatz.

"Trevor pray bumped up a weight class and did so in fashion defeating all of his opponents to claim the individual title, beating the #5 ranked wrestler in North Dakota 2-0," Dargatz said. Trevor wrestled at 126 pounds, pinning Riley Griffin of Mandan, 1:10, then he pinned Ethan Curruth of Ellendale-Edgeley-Kulm, 1:24, and in the championship match, he decisioned Darin Vangorkom of South Border, 2-0, scoring a two-point take-down in the second period.

"Brandyn Anderson kept on his winning ways also by winning the individual title as well, and wrestled a very smart and controlled championship match 7-1," Dargatz said.

Anderson, in heavyweight, pinned Riley Mattheis of Linton, in 43 seconds, then he pinned Travis Patterson of Bishop Ryan in 2:59, he pinned Seth Strong of Ellendale-Edgeley-Kulm, in 55 seconds, and in the championship match, he decisioned Lonnie Rodlund of Tiospa Zina, 7-1.

"I'm very pleased with how things went this weekend," Dargatz said. "We wrestled very smart, stayed in great position the whole day and the boys' efforts showed. It's really nice to see them performing so well this early in the year." Groton Area will be at the Northeast Conference Tourney next Saturday at Milbank. It starts at 11 a.m.



**Trevor Pray decisioned Darin Vangorkom of South Border in the championship match, 2-0.**

(Photo by Kara Anderson)



**Trevor Pray pinned Ethan Curruth of Ellendale-Edgeley-Kulm in 1:24.**

(Photo by Kara Anderson)



**Brandyn Anderson pinned Seth Strong of Ellendale-Edgeley-Kulm, in 55 seconds.**

(Photo by Kara Anderson)



**Brandyn Anderson won the championship match with a 7-1 decision over Lonnie Rodlund of Tiospa Zina.**

## Groton Prairie Mixed Team Standings:

Shih Tzus 19, Chipmunks 14, Jackelopes 12, Pocket Gophers 10, Coyotes 9, Foxes 8

**Men's High Games:** Brad Waage 232, Mike Siegler 226, Roger Spanier 215, Doug Jorgensen 211, Roger Colestock 201, Steve Giedt 200

**Women's High Games:** Darci Spanier 186, 169, Sue Stanley 172, Vicki Walter 168, Lori Giedt 168

**Men's High Series:** Brad Waage 626, Mike Siegler 590, Roger Spanier 568

**Women's High Series:** Darci Spanier 474, Lori Giedt 458, Dar Larson 457

## Conde National League

**Team Standings:** Mets 25.5, Cubs 25, Giants 19, Pirates 18, Braves 17, Colts 15.

**Men's High Games:** Lance Frohling 212, Bryce Dargatz 181, Troy Lindberg 179.

**Men's High Series:** Lance Frohling 541, Bryce Dargatz 516, Troy Lindberg 470.

**Women's High Games:** Alice Severson 173, Mary Larson 172, Michelle Johnson 168.

**Women's High Series:** Mary Larson 446, Alice Severson 445, Michelle Johnson 442.

## Groton Coffee Cup League

**Team Standings:** Jungle Lanes 27, James Valley 26, Ken's 23, Ten Pins 20.

**High Games:** Vicki Walter 212 and 178, Vickie Kramp 161, Mary Jane Jark 159.

**High Series:** Vicki Walter 534, Mary Jane Jark 438, Vickie Kramp 433.

## The Groton Independent

605/397-NEWS (6397)  
 Fax: 1-775-459-6259  
 Paul Irvin Kosel, Publisher  
 paperpaul@grotonsd.net ~ 605-397-7460  
 Tina Kosel, Office Manager  
 office@grotonsd.net ~ 605-397-7285  
 Notices: legals@grotonsd.net  
 News Items: news@grotonsd.net

Deadline to submit items: Monday at noon

Yearly Subscription Rates: 12  
 Month Rate: \$35 (includes tax)  
 The Groton Independent (USPS# 230-440) is published weekly with its periodicals postage paid at Groton, SD.  
**Postmaster: Send address changes to**  
 Groton Independent  
 110 N Washington St.  
 Groton, SD 57445

## Dr. Geoffrey Rath - Optometrist

Eye Exams Glaucoma Tests Rx's Filled  
- All Types Contact Lenses -

Doctor here Mondays Only - Office open Thursdays.  
701-349-3223 to make appointments & adjustments

Hours at Ellendale, N.D. are:  
Monday 9 - 12 & 1 - 5 Thursday 1:00 - 4:00

## Groton Chiropractic Clinic

Carol McFarland-Kutter, D.C.  
1205 N 1st St., Groton 397-8204

## Dakota Brush

Brooms, Brushes, Mops, Can Liners, Paper Products.

Brushes & Squeegees  
and Snow Shovels

**397-9337**  
104 N. Main, Groton

## Smith Thank You

To the individuals and families who contributed to our "Bridal Shower Box" at Lori's Pharmacy, Thank you so much for your generous gifts! Shane and I received many beautiful kitchen décor and serving dishes, as well as some bake and cookware. We are very excited to begin setting up our home together and have such wonderful things! I truly enjoyed being able to explain to my future in-laws the generosity of my community as I opened the gifts! They were amazed at the close-knit family and friends that I have had the privilege of being surrounded with during my time in Groton. I can only hope that the future communities Shane and I make our home in are half as welcoming as my childhood home!

Thank you so much,  
Marah Smith

## Snyder Family Thank You

A very heartfelt thank you from the family of Doc Snyder to the Classes of 1989 and 1991 for providing a special place for us to stay in Groton and to be together with extended family as we celebrated his life this week. A special thanks to all those who helped provide food and treats so generously for us here.

Thank you also to Kiersten Sombke and Vicci Stange for the extra TLC, additional food and childcare.

We appreciate all the thoughtfulness, prayers and loving support from the Groton community during this time.

## Rip 'N Ravel CFEL

The festive decorated home of hostess Linda Gengerke was the location of the Rip 'N Ravel CFEL club on December 7th. Jingle Bells was sung by the 11 members attending. Roll call was answered by your favorite Christmas song.

New booklets for 2016 were handed out. Officers are: President-Merry Jo Ball, Vice President-Carol Dohman. Secretary-Treasurer-Bonnie Erdmann.

Maralyn Hoops read a thank-you from the Brown County Fair Board for our support. The fair dates for 2016 are Aug.15-21 with the theme being 'Where Memories Are Made'.

Names of 2 families were received for our Christmas project--4 adults & 5 children. Gifts and food are to be at the City Office by Dec. 18th.

The lesson Favors for Fall & Christmas was presented by Linda & Carol Osterman.

A gift exchange of handmade items ended the meeting.. Next meeting will be January 4th with Ella Johnson as hostess.

## Groton Lions Club

The December monthly meeting of the Groton Lions Club was held last Thursday evening, with president Christ Frost leading the short business session.

Plans were made for a holiday party and potluck supper, for the monthly January meeting, Thursday, Jan. 14, at 6 pm.

Lee Schinkel proposed four new possible members to the Groton club. They were Joseph Williams, Joshua and Elizabeth Heitz, and Justin Kersten, all of Groton. All four were voted upon to become the newest members of the club.

## Groton Kiwanis

Lee Schinkel was program leader for last week's weekly dinner Kiwanis meeting.

Lee introduced Kristen Gonsoir, GHS

science instructor, debate coach, and oral debate coach.; and six of her GHS students. These students were seniors, Lily Cutler, Kelsey Iverson, and Katie Miller; juniors Keri Pappas, and Erin Smith, and sophomore, Jenifer

Fjelstad. This group, the Reader's Theater, wrote their own oral interp selections, were state qualifiers, and placed 2nd at the Watertown Invitational.

Lily Cutler was a state qualifier in poetry, and placed 5th at the

Mitchell tournament.

Erin Smith and Jenifer Fjelstad were also state qualifiers in duo interp. Keri Pappas was a state alternate in non-original oratory, and Lily Cutler was a state alternate in the humorous division.



Avera Cancer Institute Aberdeen.  
Expert cancer services, right here at home.  
Bringing hope to the fight.

Join us for  
an open house  
Thursday, Jan. 21  
1 - 4 p.m.  
Ribbon Cutting: 2 p.m.

**Avera**  
Cancer Institute  
Aberdeen

To learn more,  
go to [AveraStLukes.org](http://AveraStLukes.org)

Avera has deep roots in the Aberdeen community and for years has offered expert care. We're excited to expand our services under one roof with the opening of the Don and Carmen Meyer Center of Excellence, home of Avera Cancer Institute Aberdeen. Services will include:

- Oncology
- Chemotherapy/infusion
- Radiation therapy
- Telemedicine
- Patient navigation
- Genetic counseling
- Clinical trials/research
- Nutrition counseling
- Surgical care
- Chaplaincy
- Social work
- Massage therapy
- Therapy services
- Financial counseling
- Valet parking

Access to cancer care is easier than ever with Avera Cancer Institute Aberdeen.  
We're bringing hope to the fight in northeast South Dakota.

## Hanlon Brothers Gravel Hauling

New & Cleaning of  
Stockdams with our  
60' reach trackhoe  
**605/395-6531**

Oven Fresh Sandwiches Hot Desserts Snack Melts  
11 E Hwy 12, Groton ~ 397-8627

## BLOCKER CONSTRUCTION

NEW CONSTRUCTION  
REMODELING  
HOOP BARNs

(605) 216-2677 (605) 226-4062

## Groton Chiropractic Clinic

Carol McFarland-Kutter, D.C.  
1205 N 1st St., Groton 397-8204

"From minor scratches to a complete rebuild... we can do it all!"

## Flarris Auto Body

225 Brown County Hwy 19 South  
Aberdeen: 605/725-4900

## Dr. Geoffrey Rath - Optometrist

Eye Exams Glaucoma Tests Rx's Filled  
- All Types Contact Lenses -

Doctor here Mondays Only - Office open Thursdays.  
701-349-3223 to make appointments & adjustments

Hours at Ellendale, N.D. are:  
Monday 9 - 12 & 1 - 5 Thursday 1:00 - 4:00

## Webster Theatre

Theatre opens at 7 pm with movies starting at 7:30 pm, Friday through Monday.

**12/18 to 12/21 Mockingjay Part 2 PG13**  
**12-25 to 12-28 Merry Christmas - Closed**

## Brown County Delinquent Tax Notice

DECEMBER 1, 2015 – GENERI, SHEILA ENDERSON, TREASURER OF BROWN COUNTY, SOUTH DAKOTA, DO HEREBY CERTIFY THE TAXES AND SPECIAL ASSESSMENTS ON THE FOLLOWING LIST OF REAL AND PERSONAL PROPERTY HAVE BECOME DELINQUENT FOR THE YEAR 2014. THIS LIST MAY NOT REFLECT CHANGES IN RECORDED OWNERSHIP.

IN TESTIMONY, I, SHEILA ENDERSON, TREASURER OF BROWN COUNTY, SOUTH DAKOTA, HERETO SET MY HAND AND SEAL.

DECEMBER 1, 2015.

\$316.58 LT 1 BORDEN'S SD S2 SE 3-127-64 NAPTON, DARREL L \$28.30 LT 2 BORDEN'S SD S2 SE 3-127-64 NAPTON, DARREL L \$28.30 LT 3 BORDEN'S SD S2 SE 3-127-64 NAPTON, DARREL L \$28.30 LT 4 BORDEN'S SD S2 SE 3-127-64 NAPTON, DARREL L \$65.71 LT 5 BORDEN'S SD S2 SE 3-127-64 NAPTON, DARREL L \$28.30 LT 6 BORDEN'S SD S2 SE 3-127-64 NAPTON, DARREL L \$28.30 LT 7 BORDEN'S SD S2 SE 3-127-64 NAPTON, DARREL L \$14.27 LT 2 BK 17 HOUGHTON ENGELS, TERRI L

\$800.20 LT 1 BARNARD SCHOOL SD SW NW 13-126-64 (PT B2 REYNARD & UNP)

PRIDE, CHARLES R

\$1,079.71 S 30 RODS OF E 112 RODS SE 7-126-63 EX HWY COX, MAVIS

\$758.87 JARK OL 1 NE 29-126-62 KRUMM, NANCY K \$9.89 LT 9-10 BK 6 HOUGHTON WINBURN, HAROLD L

\$336.09 LT 1 RANDY STANLEY RPL STANLEY'S OL 1 SW 13-125-61 WALKER, THOMAS

\$479.94 SNYDER'S OLS A & B SW 31-125-60 1999 28X48 FRIENDSHIP

MY9920597ABV MEHLHOFF, ZACHARY

\$1,110.87 NE 8-125-64 HINZ, DONNIE E

\$2,014.59 SE 8-125-64 HINZ, DONNIE E

\$990.90 SW 8-125-64 HINZ, DONNIE E

\$80.55 SW CORNER OF NW 12-125-64 S&W OF ELM RIVER HINZ, DONNIE E

\$477.22 NW OF SW & PT SW OF SW 12-125-64 HINZ, DONNIE E

\$2,002.60 LT 1 ODDE ADD NE 15-125-64 BERRETH, MICHAEL

\$535.11 SW NW & NW SW 16-125-64 HINZ, DONNIE E

\$543.02 NW 18-125-64 HINZ, DONNIE E

\$536.30 NE 7-125-65 ACHEN, RICHARD A

\$3,406.50 SE 13-124-63 MCHUGH, PATRICK

\$2,502.33 NE 24-124-63 MCHUGH, PATRICK

\$2,750.72 NW 24-124-63 MCHUGH, PATRICK

\$2,163.03 SW 24-124-63 MCHUGH, PATRICK

\$1,028.55 SE 30-124-63 EXLAND PLATTED PRAY, CHAD

\$1,281.19 LT 1 T&C REED 1ST SD NW 35-124-63 REED, TIMOTHY

\$934.84 S2 NE 27-124-62 ARMANTROUT, FRANK G.

\$468.34 N2 N2 SE 27-124-62 ARMANTROUT, FRANK G.

\$551.18 REEDS OL 2 SW 30-124-62 REED, TIMOTHY M

\$986.14 N 800' OF W 466' NW 31-124-62 (8.21AC) GLEASON, EDWARD

\$3,384.16 SE 28-124-60 HOWARD, JESSE J

\$496.51 E2 SW 16-123-60 INC HOWARD CONS EASMT TRACT 1 HOWARD, JESSE J

\$321.04 E2 SE 19-123-60 N & E OF HWY EX HWY HOWARD, JESSE J

\$316.39 BK 1 COX 1ST SD JAMES (L3-5 PT 6, 29&30 JAMES OLS) 2008, FRIENDSHIP 16X80 MY0830325V COX, LENA

\$285.50LT 5 BK 6 BATH BLAIR, CHARLES

\$42.30LT 6 BK 6 BATH BLAIR, CHARLES

\$144.79E 71' LT 9-12 BK 12 BATHGLYNN, MICHAEL C

\$59.39 LT 15 BK 12 BATH HANSON, JASON

\$528.22 LT 16 BK 12 BATH HANSON, JASON

\$4,402.64 LT 2 WRIGHTS 3RD SD NE 7-123-62 FERGUSON, CHAD A.

\$514.03 LT 1 HANLON SD NE 20-123-62 FINLEY, PATRICIA

\$1,434.30 LARSONS OL 1 NW 25-123-63 INC HETTICH CONS EASE TR 1 HETTICH, LLC,

HOMESTEAD SD SE 17-123-64 (LT 6 FULKER, TOPLE, DUSTIN MICHAEL

\$54.08 S 660' OF W 330' NW NE 22-123-64 HETTICH LLC,

\$320.22 LT 1 WORRELL 1ST SD SE NE 22-123-64 (.871A) LOUT, TERRY LEE

\$693.74 DIXON OL 5 NE 26-123-64 MEIDINGER, BILL

\$213.49 LT 1 AUDITORS SD SE 27-123-64 (2.07 AC) MEIDINGER, BILL

\$111.09 LT 3 BK 2 ROTT'S MINA RANCHETTES W2 19-123-65 RICHTER, KEITH

\$1,311.65 POTT'S OL 1 NE 23-123-65 GRIESE, DONALD J

\$1,131.65 NE 23-123-65 EX HWY & EX LAND DEEDED GRIESE, DONALD J

\$1,642.65 NW 23-123-65 EX LAND DEEDED GRIESE, DONALD J

\$4,796.38 WEB-STANLEY TR 1 NE 24-123-65 WEBB-STANLEY, ARLENE P

\$770.99 W2 SE 25-121-65 BOKELHEIDE, GARY E.

\$544.29 S2 SW 25-121-65 BOKELHEIDE, GARY E.

\$565.93 N2 SW 25-121-65 BOKELHEIDE, GARY E.

\$198.11 S2 NE 36-121-65 BOKELHEIDE, GARY E.

\$174.44 N2 NE 36-121-65 BOKELHEIDE, GARY E.

\$250.10 NE OF NW 36-121-65 BOKELHEIDE, GARY E.

\$281.90 SE OF NW 36-121-65 BOKELHEIDE, GARY E.

\$292.78 NW OF NW 36-121-65 BOKELHEIDE, GARY E.

\$6.60 LTS 23 BK 4 MANSFIELD SE 32-121-64 BIERMAN, BRYAN

\$17.51 LT 9 BK 3 MOULTON'S 1ST SD SE 2-122-64 VOSIKA, CHRISTOPHER

\$13.93 LT 10 BK 3 MOULTON'S 1ST SD SE 2-122-64 VOSIKA, CHRISTOPHER

\$1,362.61 REHFELD'S 2ND ADD SW 25-121-64 1981 BONAVILLA 16X80 18A10748, MITCHELL, NANCY A.

\$1,073.02 W2 SE 29-121-64 & NASH CONS EASMT TRACT 1 NASH, DONALD R.

\$844.01 S2 W2 E2 13-122-60 SCHWAB, CARL

\$2,186.14 NW 26-122-60 PIGORS, DIANNE

\$226.60 LT 11-12 & S 5' LT 13 WAREHOUSE LOTS FERNEY SW 31-122-60, PIGORS, CHRISTOPHER

\$831.15 LT 1 HAGAN SD SW 20-121-62 EX LT 1A 1994 28X76 FRIE (MH), MY9412694ABV HAGAN, SCOTT N

\$54.92 LT 6 BK 1 RO-JU-OS PARK SE 8-128-65 YDE, THEODORE R III

\$242.66 E 340' OF W 1465' OF S 321' SW 2-128-65 MONROE, SARAH A

\$1,282.98 LT 3-4 & E2 SW 7-128-65 KLIPFEL, MICHAEL J

\$526.21 LT 11 THORPES 4TH ELM LAKE SD E2 17-128-65 GIBSON, AMANDA M

\$238.08 NW SW 21-128-65 EX LAKE THORPE RANCH INC,

\$463.85 N2 NW 12-128-64 GAYMAN, ELMA M

\$508.81 S2 NW 12-128-64 GAYMAN, ELMA M

\$796.09 SE 3-128-62 EX LAND DEEDED HANSEN, RAYMOND

\$1,510.25 W 2' LT 4 & E 22' LT 5 BOYD'S SD LT 1-5 BK 5 ORIGINAL PLAT, BERDEEN WILSON, SILAS A

\$1,319.45 LT 12 BK 11 ORIGINAL PLAT 224 HOLDINGS LLC,

\$1,179.63 LT 1 BURN'S RAR LT 5-6 BK 20 1ST ADD HINZ, DONNIE E

\$1,836.24 LT 3 SEDGWICK SMITH'S 2ND OF N 106.5' LT 1-3 BK 37 2ND ADD, WALTER, NICOLE M

\$668.97 LT 4 BK 42 2ND ADD HASSEBROOK, DEAN R

\$2,604.18 LT 10 BK 42 2ND ADD MARTIN, TIM

\$539.08 LT 5 BK 43 2ND ADD WEISZ, KAREN

\$689.19 S 92' LT 7 BK 43 2ND ADD E & T FREEDOM PROPERTIES LLC,

\$1,020.78 LT 9 BK 44 2ND ADD MILLER, PETE

\$229.77 S 21' LT 6 BK 50 2ND ADD GISI, DONALD P.

\$576.85 S 6' LT 1 & LT 2 KUPFERS RPL N2 LT 7-10 BK 57 2ND ADD, FISCHER, JOSEPH

\$1,351.65 W2 LT 6 BK 4 NORTH ABDN ADD FLANNERY, ELIZABETH

\$1,144.57 LT 8 BK 4 NORTH ABDN ADD SCOTT, STEVE

\$558.80 W 50' LT 1 BK 5 NORTH ABDN ADD SHISHNIA, KEITH J

\$544.60 S2 LT 9 BK 12 NORTH ABDN ADD JORDAN, DARLENE A.

\$524.49 LT 2 WELSH'S RPL OF LT 7-8 BK 33 BENNETT & THOMAS ADD, GEFFRE, KEITH

\$716.91 LT 9 & S2 LT 10 BK 41 BENNETT & THOMAS ADD SIMON, CAROLYN A

\$374.46 35.5' W OF E 35.5' N2 LT 10 & 35.5' W OF E 35.5' LT 11-12 BK 41, BENNETT & THOMAS ADD HINZE, BRIAN R.

\$608.77 LT 13 & S 25.5' LT 14 GAGE'S 1ST RPL BK 43 BENNETT & THOMAS ADD, WAHL, ELDON M

\$252.60 N 10' LT 14 & S 26' LT 15 GAGE'S 1ST RPL BK 43 BENNETT & THOMAS ADD WAHL, ELDON M

\$1,498.32 D-N-D SD BK 48 BENNETT & THOMAS ADD DND INCORPORATED,

\$385.91 LT 5 BK 50 BENNETT & THOMAS ADD WALKER, RAYMOND W

\$1,563.50 LT 1 SEARLE & HEDGERS RPL OF LT 7-12 BK 4 SULLIVAN & EASTON ADD, SIKKINK, SCOTT G

\$2,422.39 LT 1-2 BK 10 SULLIVAN & EASTON ADD LEIDHOLT, KYLE

\$2,506.45 LT 11-12 BK 12 SULLIVAN & EASTON ADD KIEFER, TRAVIS

\$2,170.30 LT 19-20 BK 5 CORRECTED PLAT OF HIGHLANDS BURDETTE, BRADLEY R

\$2,738.06 LT 1-6 BK 11 CORRECTED PLAT OF HIGHLANDS BORMES, KAROL

\$2,825.91 LT 1 PITZ 1ST SD (PT LT 23-24 BK 11 CORRECTED PLAT OF HIGHLANDS) PITZ, THOMAS J (SUBJECT TO PRIOR TAXES)

\$4,085.23 LT 2 PITZ 1ST SD (PT LT 23-24 BK 11 CORRECTED PLAT OF HIGHLANDS) PITZ, THOMAS J (SUBJECT TO PRIOR TAXES)

\$522.91 LT 3 BK 2 LAKEVIEW 1ST RPL SCHEEL, JEFFREY E

\$1,425.79 #4 GOOD SHEPHERD LUTHERAN CHURCH 1ST SD (L2-4)(UNIT & GARAGE) MCCULLOUGH, IVA H

\$544.64 LT 5 BK 14 1ST ADD TO HIGHLANDS RAU, ROBIN

\$2,135.38 LT 3 BK 23 1ST ADD TO HIGHLANDS BENGSTON, CHRISTY

\$3,209.07 LT 1-2 WESTALL RPL OF LT 5-6 BK 25 1ST ADD TO HIGHLANDS JOHNSON, DIANE L.

\$2,811.72 LT 35 BK 9 6TH ADD TO HIGHLAND NORTH NEWCOMB, ELMER E

\$1,293.58 LT 1 BK 10 6TH ADD TO HIGHLAND NORTH KRUMM, IRENE E.

\$3,069.86 LT 1 BK 16 13TH ADD TO HIGHLAND NORTH PITZ, THOMAS J

\$3,123.65 LT 21 BK 18 14TH ADD TO HIGHLAND NORTH BEARHEELS, JEROME L

\$1,307.92 LT 2 BK 2 NORTHVIEW 3RD ADD MILLS, LENA F

\$2,188.85 E 56' LT 6 BK 2 NORTH VIEW 3RD ADD HINZ, THOMAS L

\$16.45 LT 28 GUGEL'S 2ND SD SW 6-123-63 SPRINKEL, ANDREW K

\$543.19 LT 7 LADNER'S RPL BK 1 HAGERTY & LLOYD ADD CAMLIN INVESTMENTS,

\$802.47 LT 12-13 BK 5 HAGERTY & LLOYD ADD ABERDEEN ANNIS, BREE'N L

\$464.37 LT 14 KELLEY'S RPL BK 15 HAGERTY & LLOYD ADD HINZ, DONNIE E

\$857.18 LT 2 C H ALLEN SD BK 22 HAGERTY & LLOYD ADD GEFFRE, KEITH

\$797.89 LT 14-15 BK 22 HAGERTY & LLOYD ADD HALDER, LANNA

\$1394.73 E2 LT 18 & 19 BK 22 HAGERTY & LLOYD ADD BADGER, SHAWN

\$1,297.53 LT 12 BK 28 HAGERTY & LLOYD ADD BURDETTE, BRADLEY R

\$1,088.74 LT 5-6 RUSSELLS 1ST RAR BK 30 HAGERTY & LLOYD ADD, HUBERT, EUGENE K.

\$1,109.89 LT 3 & N 19' LT 4 BK 34 HAGERTY & LLOYD ADD BEACHAIR, ENTERPRISES LLC,

\$386.53 E 41' W2 LT 10-12 BK 34 HAGERTY & LLOYD ADD GERVEN, KEITH H

\$626.41 LT 4 BK 36 HAGERTY & LLOYD ADD SEVERSON, NOLAN

\$647.71 LT 3 BK 43 HAGERTY & LLOYD ADD STEWART, LARRY B

\$619.50 S 14' LT 7 & LT 8 BK 44 HAGERTY & LLOYD ADD RABINE, MICHELLE

\$804.29 LT 13-14 BK 45 HAGERTY & LLOYD ADD FISCHER, JOSEPH

\$446.24 N 24' LT 10 BK 46 HAGERTY & LLOYD ADD TURMAN, KRISTIN

\$894.34 LT 16 BK 46 HAGERTY & LLOYD ADD WALKER, BART

\$1,500.23 N2 LT 23-24 BK 49 HAGERTY & LLOYD ADD HINZ, DONNIE E

\$1,397.28 LT 1-2 BK 53 HAGERTY & LLOYD ADD SHISHNIA, KEITH J

\$278.43 N 92' LT 2 BK 56 HAGERTY & LLOYD ADD (GARAGE) FOGEL, WAYNE J

\$1,902.38 S 44' OF W2 LT 8 & S 44' LT 9-12 BK 75 HAGERTY & LLOYD ADD, SCARROTT, JOHN E

\$6,098.81 LT 7-12 BK 92 & S 32' LT 44 & LT 45-47 & N 16' LT 48 1ST ADD ON, W SIDE OF BK 92 HAGERTY & LLOYD ADD LEARNING CENTER LLC,

\$2,080.28 N 40' LT 6 BK 5 THOMAS ADD PARSLEY, MARTIN

\$1,548.49 LT 3 BK 12 THOMAS ADD ISAACSON, KEVIN H.

\$305.76 LT 4 & E 33' LT 5 BK 13 THOMAS ADD MIELKE, MICHAEL

\$1,090.35 E 100' LT 5 BK 14 THOMAS ADD TAMPARY, THEODORE C

\$1,053.62 LT 6 BK 19 THOMAS ADD EVANGELISTO, LEONARD A

\$482.10 LT 10 BK 19 THOMAS ADD CARLSON, TERRY L

\$1,494.26 LT 3-4 BK 33 THOMAS ADD BRENNER BUILDERS INC,

\$501.78 E 50' LT 7 BK 33 THOMAS ADD MCHUGH, PATRICK

\$1,047.89 LT 7 BK 34 THOMAS ADD BEACHAIR ENTERPRISES LLC,

\$1,162.67 LT 1 EX S 2'3" ANNA KAVENS SD LT 6 BK 35 THOMAS ADD ORR, ROBERT

\$630.20 LT 7 BK 39 THOMAS ADD SEVERSON, JEFFREY R

\$1,201.40 LT 1 SCHMIDT 1ST ADD (B39 THOMAS) MOORE, BARBARA

\$1,574.64 E 101' LT 1 BK 50 THOMAS ADD CONN, DIANE M.

\$1,260.20 N 40' LT 6 BK 5 SIMMONS 1ST ADD SVARSTAD, KAYDEN N

\$1,734.86 LT 1-2 BK 19 & S 15' LT 8 BK 16 & 50' E & ADJ LT 1-2 BK 19, SIMMONS 1ST ADD FRACHISEUR, JOSHUA

\$3,099.62 LT 11 & N 15' LT 12 BK 25 SIMMONS 1ST ADD & 50' IMMEDIATE & ADJ, JOHNSON, MARK A.

\$304.80 S 123' W 50' RR ROW ADJACENT TO LT 17 BK 25 SIMMONS 1ST ADD, CHICAGO & NORTHWESTERN RR

\$724.23 LT 19 BK 1 NORMAL ADD GONSOR, SIDNEY

\$768.40 S 40' LT 20 BK 1 NORMAL ADD GONSOR, SIDNEY

\$2,501.99 LT 5 BK 3 RPL BK 3-4 HUFFMANS 2ND ADD FINSTAD, CHERYL A.

\$984.01 LT 2 BK 5 GORDERS 2ND ADD COX, JASON

\$482.50 LT 9 BK 5 GORDERS 2ND ADD EMMETT, SANDRA K

\$2,740.33 LT 16 BK 3 GORDERS RPL 4TH ADD EX LT H1 MALSAM, JON

\$1,171.98 LT 22 BK 6 GORDERS RPL 4TH ADD HENRICH, STEVEN W.

\$2,136.11 LT 7 BK 7 GORDERS RPL 4TH ADD MIELKE, MICHAEL

\$1,060.44 LT 9 BUNNESS SD BK 31 WEST ABDN ADD BLOCK, MICHAEL

\$1,695.83 N 47' LT 7-12 BK 35 WEST ABDN ADD NEWCOMB, ELMER E

\$959.58 LT 5-6 BK 40 WEST ABDN ADD ABERDEEN PROPERTIES LLC,

\$1,241.64 W 12.5' LT 11 & LT 12 BK 41 WEST ABDN ADD JUNG, JOSHUA

\$1,586.13 LT 12 BK 11 WEST HILL ADD PALM, NESTER

\$508.57 E 25' LT 8 & W 12.5' LT 9 BK 14 WEST HILL ADD MCCOY, DAVID

\$1,286.83 LT 2 BK 15 WEST HILL ADD & N 8' V/A HAUCK, JAMES

\$8,801.22 LT 1 SWANSON ELECTRIC ADD ABERDEEN (ARTZ OL 1) CROSSROADS REAL ESTATE LLC,

\$870.11 E 100' OF S 142' OF N 1/2 OL B I.S.DAYTONS OL (BK 2 HIGHLAND PARK ADD) ERDMANN PROPERTIES,

\$1,928.64 LT 6 BK 17 HIGHLAND PARK ADD & 32' S LT 6 ADJ TO 9TH AVE SW MALSAM, JON

\$14.91 E 2' LT 12 BK 18 HIGHLAND PARK ADD WALKER, BART

\$162.09 LT 4 BK 23 HIGHLAND PARK ADD & 32' ADJ TO 9TH AVE SW CLARK, SUSAN HOPPER

\$1,839.39 SCHIPKE 1ST SD LT 2 NE 22-123-64 (.65 A) SCHIPKE, STEWART K

\$299.08 E 83' LT 2 BK 3 PLEASANT HILL ADD MALSAM, JON

\$127.03 N 44' LT 5-7 BK 5 PLEASANT HILL ADD LIPP, LEON

\$289.00

RONALD  
\$137.92 LT 1-3 & LT 4 EX THE SW 25' BK 12 ORIG PL CLAREMONT NEHLS, RONALD  
\$659.44 LT 8-12 BK 1 ORIG PL COLUMBIA REED, TIMOTHY M  
\$70.94 LT 3 COLUMBIA RR ADD NW 28-125-62 COLUMBIA REED, TIMOTHY M  
\$41.30 MILL ST BALDWINS 1ST ADD 301,303,305,307 309,311,313,315,317,319,321,323,325 REED, TIMOTHY M  
\$37.56 BROADWAY BALDWINS 1ST ADD LT 302,304,306,308,310,312,314,316,318,320,322,324,326,328 REED, TIMOTHY M  
\$85.91 MILL STREET PECK'S 1ST ADD LT 201,203,205,207,209,211,213,215,217,219,221,223,225,227,229,231 REED, TIMOTHY M  
\$88.65 BROADWAY PECKS 1ST ADDN. E 1/2 OF LOTS 101,103,105,107,109 BROWN, THOMAS E  
\$94.99 BROADWAY PECKS 1ST ADD LT 202,204,206,208,210,212,214,216,218,220,222,224,226,228,230,232 REED, TIMOTHY M  
\$23.36 LT 5 BK 4 STRATFORD HANSEN, MICHAEL M  
\$23.36 LT 6 BK 4 STRATFORD HANSEN, MICHAEL M  
\$342.97 LT 4-6 BK 5 STRATFORD RECK, DERRICK  
\$20.59 LT 1 BK 7 STRATFORD MACHAN, RONALD R  
\$180.21 LT 7-9 BK 7 STRATFORD WALBERG, AMANDA  
\$47.91 LT 13-14 BK 17 STRATFORD HANSEN, MICHAEL M  
\$123.08 LT 9 BK 19 STRATFORD HANSEN, MICHAEL M  
\$59.77 LT 10-12 BK 19 STRATFORD MOSBRUCKER, CHARLES  
\$78.17 LT 1-2 & 11-12 BK 20 STRATFORD HANSEN, MICHAEL M  
\$499.57 LT 1-3 BK 25 STRATFORD DEVRIES, DARIN L  
\$582.82 HENLEY OL A SW 20-124-61 INC PRAY ADD PRAY, CHAD  
\$272.62 TR 1 SCHOPPE SW 22-124-61 ACKERMAN, JON  
\$779.33 N2 NW 10-128-61 DANIELS, TODD J.  
\$30.17 LT 4 BK 8 WESTPORT SCHOENFELDER, BECKY  
\$17.85 LT 6 BK 8 WESTPORT SCHOENFELDER, BECKY  
\$9.56 PT LT 3 MATTESONS 2ND SD BEG 110.5' SW FROM NE CORNER LT 3, 50' NW AT RIGHT ANGLE TO SE LINE LT 3 & SOUTHWESTERLY TO S LINE LT 3 MATTESONS 2ND SD MARSKE, DEAN A  
\$1,215.05 LT 5-6 BK 8 WARNER MITCHELL, NANCY A.  
\$459.47 LT 2 GRAHAM/HASE ADD BK 12 & 8' V/A WARNER ESKE, RIECK J  
\$583.98 LT 3-4 & E 25' LT 10 & LT 11-12 BK 14 & 8' V/A WARNER SEAMAN, BRAD  
\$1,409.34 LT 2 BK 3 GREEN MEADOWS ADD WARNER THORSNESS, DEBORAH A

#### MOBILE HOMES:

\$8.14 W2 N2 SW 2-127-64 1972 MEDALLION NAPTON, DANIEL  
\$35.79 LT 3 REMEDE'S ADD MANFIELD 1969 GREAT LAKES LEFFORGE, GARY  
\$7.45 SW 13-123-63 1974 SKYLINE MITCHELL, NANCY A.  
\$50.10 112 2ND CURVE 1973 HILLCREST ABERDEEN ESTATES LLC,  
\$56.02 928 9TH CURVE 1973 HOUSE OF HARMONY ABERDEEN ESTATES LLC,  
\$75.68 114 1ST CURVE 1974 SCHULT ABERDEEN MOBILE HOME PARK,  
\$26.04 EISENBIES COURT #41 1968 RICHARDSON 260M2B31565 ANDERSON, COLIN  
\$85.50 114 7TH CURVE 1974 GUERDON INDS ARNDT, WILLIAM & PETERMAN, MARY  
\$51.10 107 7TH CURVE 1973 ASTRA ARNOLD, RONALD & SANDRA  
\$56.02 LAKESIDE ESTATES 109 6TH CURVE 1976 MARSHFIELD BADGER, JANICE  
\$53.87 LAKESIDE ESTATES 202 7TH CURVE 1972 KENWOOD BECKER, SHERRI  
\$54.09 PARK VILLAGE #312 1971 DETROITER BETTER LIVING HOMES, LLC,  
\$60.71 LAKESIDE ESTATES 113 2ND CURVE 1975 FLAMINGO CROWE, JAMANE  
\$55.83 EISENBEIS COURT #1 1970 DELTA DALE, MARIANNE OR ANNA  
\$50.10 LAKESIDE ESTATES 204 3RD CURVE 1971 DICKMAN DOLL, NALEEN ESTATE (SUBJ TO PRIOR TAX)  
\$54.83 EISENBIES COURT #17 1969 KENWOOD EPPARD, JEREMY  
\$29.67 LAKESIDE ESTATES 105 5TH CURVE 1975 HOLLY FRANKS, CHARLES  
\$72.45 LAKESIDE ESTATES 208 6TH CURVE 1973 ADRIAN FREY, DENNIS J.  
\$60.94 DELAVILLA COURT 218 S ILLINOIS ST 1973 ROLLOHOME GRESSETH, CAROLE A  
\$67.74 LAKESIDE ESTATES 204 4TH CURVE 1974 WINDSOR

GRIFFITHS, ARLENE  
\$68.87 PARK VILLAGE #105 1974 CLIFTON COTTAGE HARDY, HELEN L  
\$50.10 LAKESIDE ESTATES 202 5TH CURVE 1976 ADRIAN HENRY, ANNIE  
\$36.38 LAKESIDE ESTATES 105 E LAKE DR 1968 MARSHFIELD JENSEN, JAMES  
\$56.02 LAKESIDE ESTATES 930 9TH CURVE 1970 RITZ JOB, STACEY  
\$76.68 109 8TH CURVE 1973 MARSHFIELD JOHNSON, ROGER OR LEE  
\$60.71 EISENBEIS COURT #85 1970 AMERICAN HOME-DALE KRAMP, ERIC  
\$73.45 LAKESIDE ESTATES 101 6TH CURVE 1976 REGAL LEE, LISA & JIM  
\$60.71 LAKESIDE ESTATES 205 6TH CURVE 1965 ALMA MORISSETTE, NICOLE  
\$50.10 LAKESIDE ESTATES 105 8TH CURVE 1975 BUDDY NELSON, TARA  
\$84.50 LAKESIDE ESTATES 113 1ST CURVE 1975 SCHULT PHARRIS, CINDY  
\$50.10 EISENBIES COURT #97 1975 WINDSOR POIRIER, TAWNY  
\$84.50 918 9TH CURVE 1973 MARSHFIELD RERNLEITNER, KENNETH L  
\$84.50 LAKESIDE ESTATES 206 3RD CURVE 1972 SHARVAL ROBERSON, JON  
\$49.71 LAKESIDE ESTATES 203 3RD CURVE 1972 SCHURTT, JAIMIE  
\$80.01 EISENBEIS COURT #16 1972 INDY SCHWABE, TRIXY (SUBJ TO PRIOR TAX)  
\$92.87 EISENBEIS COURT #81 1974 HOUSE OF HARMONY SELZLER, CASSANDRA OR HOLTEY, JEREMY  
\$70.79 PARK VILLAGE #811 1970 BUDDY SHEETS, RICHARD & RITA  
\$57.02 213 6TH CURVE 1973 TITAN SMITH, KAREN & SHELBY (SUBJ TO PRIOR TAX)  
\$75.68 PARK VILLAGE #713 1970 MAGNOLIA ST CLAIR, JOLEEN  
\$44.50 EISENBEIS COURT #30 1973 HOUSE OF HARMONY SWEARINGEN, AMANDA & RICHARD  
\$60.94 LAKESIDE ESTATES 111 3RD CURVE 1976 BUDDY WILSON, BERT  
\$45.93 COUNTRY VILLAGE #10 1975 WESTERN HOMES LINDGREN, AMANDA LYNN  
\$57.82 NE 1/4 36-124-64 1962 NEWMOON NOLTNER, JESSE  
\$61.91 BROADWAY PECKS 1ST ADDN. LT 16 1969 DETROITER ACKERMAN, DANIEL  
\$54.32 ESPLANADE PECKS 3RD ADDN. LTS 102 & 104 1974 RUSHMORE KAMPA, COLE

#### BUILDINGS ON LEASED SITE:

\$38.19 BOLS LT 1 RANDY STANLEY RPL STANLEY'S OL 1 SW 13-125-61 1985 COME 14X60 #KJ04264A WALKER, THOMAS M  
\$158.58 TACOMA PARK 23-124-62 BOLS #1 WEST SIDE FROM N DEMARCE, WILLIAM G  
\$87.85 BOLS NW 21-124-60 (QUONSET ) KRUEGER, RONALD N.  
\$386.67 BOLS LT 2 HANLON SD NE 20-123-62 1997 SCHULTZ 16X80 R276829 ROHRBACH, KEVIN  
\$183.07 BOLS LT 1 HANLON SD NE 20-123-62 1981 DETROITER 16X80 MNDH04D21120981A (MH) FINLEY, PATRICIA & GAREY  
\$36.35 BOLS S2 34-123-63 (BINS) JENSEN, BILLY K.  
\$1,544.34 BOLS LT 2 BK 2 NORTHWOOD 1ST SD NE 6-123-63 1998 FRIENDSHIP, 28X80 MY9818871ABV (MH) ACKERMAN, WAYNE A  
\$570.56 BOLS THE MEADOWS #7 NE 2-122-64 1996 HIGH #HK5846AB ENGSTROM, CARY & RICHELIS, VEEDA  
\$249.48 BOLS THE MEADOWS #19 NE 2-122-64 1985 DETROITER VIN# 0503068 PIEHL, ADAM ORLYNN  
\$1299.60 BOLS THE MEADOWS #28 NE 2-122-64 2003 FRIENDSHIP 28x80 MY-0325445ABV KESTER, DENISE  
\$368.66 BOLS THE MEADOWS #35 NE 2-122-64 1995 16X76 FRIENDSHIP MY9513899V ERICKSON, JEFF & TAMMY  
\$1,884.94 BOLS SE 12-122-64 2009 FRIENDSHIP MY-0931400ABV WALTER, AMY M & DUNLAVY, ALLEN  
\$221.11 BOLS SW 20-121-62 (MH) 1997 SCHULTZ 16X80 R276347 HAGAN, SCOTT N & NORMAN  
\$74.58 BOLS #302 PARK VLG LT 2 BK 1 PARK VLG 1981 DETROITER 16X64 MNDH-04D08119661A KNAPP, JAMES A  
\$335.09 BOLS #314 PARK VLG LT 2 BK 1 PARK VLG 1996 FRIENDSHIP 14X70 MY9616030V REED, TONI & WILLIAM  
\$108.39 BOLS #801 PARK VLG LT 2 BK 1 PARK VLG 1983 COLT 14X60 9021 BAIN, LARRY  
\$62.42 BOLS #814 PARK VLG LT 2 BK 1 1981 MODULINE 64284 GREER, RON & VICKIE

\$1,049.72 BOLS #1002 PARK VLG LT 2 BK 1 1998 HIMI HM7689A LECOMPTE, MARTY & KIRA  
\$552.72 BOLS #1008 PARK VLG LT 2 BK 1 1997 HOMA MNHM9629401A HOFFMANN, NORA  
\$475.41 BOLS #1009 PARK VLG LT 2 BK 1 1996 HIGHLANDER HK6045 CADY, TONI M  
\$401.87 BOLS #1010 PARK VLG LT 2 BK 1 1994 FRIENDSHIP MY9411999V STUGELMEYER, EVAN B & DANIELLE  
\$528.80 BOLS #1023 PARK VLG LT 2 BK 1 1996 FRIENDSHIP MY9614785ABV PETERSON, SHEILA  
\$655.19 BOLS #1024 PARK VLG LT 2 BK 1 1996 FRIENDSHIP 28X56 MY9615591ABV & GARAGE LECOMPTE, PATRICIA K  
\$271.72 BOLS #1218 PARK VLG LT 2 BK 1 1992 FRIENDSHIP MY929823ABV SCHAUNAMAN, SHARON  
\$511.17 BOLS #1219 PARK VLG LT 2 BK 1 2001 FRIENDSHIP MY0123210V LOU, TERRY L  
\$350.17 BOLS #1231 PARK VLG LT 2 BK 1 1997 FRIENDSHIP MY9716288V WALZ, JACQUELINE M.  
\$131.89 BOLS #1234 PARK VLG LT 2 BK 1 1997 HIMI HL6670AB WISE, ASHLY  
\$534.69 BOLS #1243 PARK VLG LT 2 BK 1 1996 FRIENDSHIP MY9615841V MOFFENBIER, STAN  
\$151.33 BOLS #69 EISENBEIS CT S 300' LT 1 PIERSONS SD & N2 V/S (1ST AVE SE) 18-123-63 EX HWY 1983 MODULINE 14X70 64995 SOBESKI, KENNETH L  
\$245.83 BOLS #82 EISENBEIS CT S 300' LT 1 PIERSONS SD & N2 V/S (1ST AVE SE) 18-123-63 EX HWY 1986 DETROITER THORNTON, CARMEN  
\$246.96 BOLS #96 EISENBIES CT S 300' LT 1 PIERSONS SD & N2 V/S (1ST AVE SE) 18-123-63 EX HWY 1990 FRIENDSHIP MY907769V BONNET, MARVIN  
\$238.04 BOLS #104 EISENBEIS CT S 300' LT 1 PIERSONS SD & N2 V/S (1ST AVE SE) 18-123-63 EX HWY 1985 COMP HARTY, STACY & SABRINA  
\$460.93 BOLS LT 4 BK 27 ROCHES EAST SIDE ADD 1994 HIGHLAND SCHMITT, JOY  
\$681.46 BOLS LT 1 LAKESIDE 1ST ADD W2 26-123-64 (85.9 A) 2005 SUMMERBROOK FS216754 ABERDEEN LAKESIDE LLP,  
\$413.29 BOLS LAKESIDE EST W2 26-123-64 1988 SCHULT WAKELY,SANDY K & RALPH  
\$107.58 BOLS LAKESIDE EST W2 26-123-64 (MH) 1983 REDMAN 16X80 1023720 ABERDEEN MOBILE HOME PARK,  
\$247.98 BOLS LAKESIDE EST W2 26-123-64 1990 MEDALLION 16X85 VIN# 2993C ABERDEEN ESTATES LLC,  
\$251.94 BOLS LAKESIDE EST W2 26-123-64 1987 FRIENDSHIP LOUT, TERRY LEE  
\$200.33 BOLS LAKESIDE EST W2 26-123-64 1982 DETROITER 16X80 MNDH04D17224681A ABERDEEN MOBILE HOME PARK,  
\$1101.16 BOLS LAKESIDE EST W2 26-123-64 1999 SCHULTZ 16X80 VIN# M291487 PROGRESSIVE HOUSING & FINANCE II, LLC,  
\$97.43 BOLS LAKESIDE EST W2 26-123-64 1978 RITZCRAFT ESSER, ANASTASIA C & KATRINA  
\$740.37 BOLS LAKESIDE EST W2 26-123-64 1994 SCHULT 16 X 80 (NO TITLE) ABERDEEN MOBILE HOME PARK,  
\$31.95 BOLS LAKESIDE EST W2 26-123-64 1983 MODULINE 16X74 64901 ABERDEEN MOBILE HOME PARK,  
\$457.89 BOLS LAKESIDE EST W2 26-123-64 1994 SCHULTZ GRENZ,DAVID & SHIRLEY  
\$108.08 BOLS LAKESIDE EST W2 26-123-64 1980 CHAMPION 24X60 0500036592AB PROGRESSIVE HOUSING & FINANCE II, LLC,  
\$63.90 BOLS LAKESIDE EST W2 26-123-64 1980 GUERDON 14X60 GDMASD34772586 ABERDEEN ESTATES LLC,  
\$283.34 BOLS LAKESIDE EST W2 26-123-64 1993 FRIENDSHIP 16X80 MY9311114V ABERDEEN ESTATES LLC,  
\$439.25 BOLS LAKESIDE EST W2 26-123-64 2008 SPRINGDALE FH104808 MID STATE HOMES LLC,  
\$691.99 BOLS LAKESIDE EST W2 26-123-64 2006 FOUR SEASON BULLIS, MARGARET  
\$301.97 BOLS LAKESIDE EST W2 26-123-64 1993 HIGH 16 X 80 HH3667 ABERDEEN ESTATES LLC,  
\$133.28 BOLS LAKESIDE EST W2 26-123-64 1979 DETROITER ELAM, TAMALYN  
\$205.55 BOLS LAKESIDE EST W2 26-123-64 1980 REGAL 26X56 3675UX ABERDEEN ESTATES LLC,  
\$161.62 BOLS LAKESIDE EST W2 26-123-64 1984 SCHULTZ 16X76 191824 ABERDEEN ESTATES LLC,  
\$236.52 BOLS LAKESIDE EST W2 26-123-64 1988 MARW 16X80 60430 ABERDEEN ESTATES LLC,  
\$150.23 BOLS LAKESIDE EST

W2 26-123-64 1985 CHII ELVERUD, DEREK  
\$107.05 BOLS LAKESIDE EST W2 26-123-64 1979 SHILO RANKIN, JOHN M & KURTZ, PEGGY  
\$191.53 BOLS LAKESIDE EST W2 26-123-64 (MH) 1989 MEDALLION 16X80 2557C ABERDEEN ESTATES LLC,  
\$97.51 BOLS LAKESIDE EST W2 26-123-64 1979 HOMEMADE HASVOLD, DENNIS & NEWELL, DIANE (SUBJ TO PRIOR TAX)  
\$275.13 BOLS LAKESIDE EST W2 26-123-64 1984 DETROITER RHYNER, ALISHA  
\$54.07 BOLS LAKESIDE EST W2 26-123-64 1979 LIBERTY 14X70 S# 06L13794 (MH) TITLE: Y86582 ABERDEEN MOBILE HOME PARK,  
\$195.22 BOLS LAKESIDE EST W2 26-123-64 1995 FRIENDSHIP MY9513973V ABERDEEN MOBILE HOME PARK,  
\$64.91 BOLS LAKESIDE EST W2 26-123-64 1977 ARTCRAFT TIGER, DEBORAH  
\$121.10 BOLS LAKESIDE EST W2 26-123-64 1978 STAT SARVIS, DAVID M & WANDA  
\$240.89 BOLS LAKESIDE EST W2 26-123-64 1997 DUTCH ABERDEEN ESTATES LLC  
\$782.98 BOLS LAKESIDE EST W2 26-123-64 2001 CENT MY01115412K CHASE MANHATTAN BANK USA,  
\$270.68 BOLS LAKESIDE EST W2 26-123-64 1993 HIGHLAND 16 X 80 #HH3598 BBB FINANCIAL LLC,  
\$285.32 BOLS LAKESIDE EST W2 26-123-64 1982 ARTC 21260 ABERDEEN ESTATES LLC,  
\$149.66 BOLS LAKESIDE EST W2 26-123-64 1982 ARTC 21260 ABERDEEN ESTATES LLC,  
\$158.17 BOLS LAKESIDE EST W2 26-123-64 (MH) 1990 CHEIF 16X76 09A18379 ABERDEEN ESTATES LLC,  
\$257.24 BOLS LAKESIDE EST W2 26-123-64 1974 MODULINE 28X56 VIN# 197700 ABERDEEN MOBILE HOME PARK,  
\$124.19 BOLS LAKESIDE EST W2 26-123-64 1979 GREAT LAKES14X70 GDMASD37793100 ELLENBECKER, DALLAS  
\$343.23 BOLS LAKESIDE EST W2 26-123-64 1984 MARSHALL 16X70 VIN# 47394 ABERDEEN MOBILE HOME PARK,  
\$174.58 BOLS LAKESIDE EST W2 26-123-64 1986 SCHULTZ 198996 ABERDEEN MOBILE HOME PARK,  
\$873.99 BOLS LAKESIDE EST W2 26-123-64 2000 SCHULT 293167 MYERS, ERIC & MICHAEL  
\$78.62 BOLS LAKESIDE EST W2 26-123-64 1978 ARTCRAFT 14X70 RV11541 (MH & GARAGE) BALDWIN, LARK L  
\$283.04 BOLS LAKESIDE EST W2 26-123-64 2002 LIBH 16X80 05L29838 ABERDEEN ESTATES LLC,  
\$1,863.73 BOLS (HOUSE) NE 19-122-65 SOLLIE, LEONARD C.  
\$152.36 BOLS NE 7-127-63 (SHOP) NICKELSON, DONALD M  
\$24.83 BOLS LT 2 PATTON'S 1ST SD SW 26-125-64 1978 LIBERTY PATTON, SHAWN  
\$73.35 BOLS LT 2 PATTON'S 1ST SD SW 26-125-64 1977 DETROITER 24X44 MNDH-04D0675162A PATTON, RONALD  
\$54.69 BOLS LT 2 PATTON'S 1ST SD SW 26-125-64 1986 FRIENDSHIP MY863712V PATTON, SHAWN  
\$267.66 BOLS LT 1 WIKI SW 27-124-64 1994 HIMI WIKI, STEPHANIE L & TANNER  
\$435.45 BOLS GAGES OL 1 NW 27-125-64 2006 SCHULTZ ROEBUCK, ROY W & DEBORAH  
\$273.90 BOLS COUNTRY VLG #1 SW 34-124-64 1993 FRIENDSHIP MY9310959V(MH) CATALANO, STEVEN G  
\$57.84 BOLS COUNTRY VLG #28 SW 34-124-64 1977 MARSHFIELD OLSON, JACALYN  
\$468.01 BOLS COUNTRY VLG #37 SW 34-124-64 1999 MEDALLION 18X85 5781M HETTICH, STEVEN & TRIXIE  
\$47.11 BOLS COUNTRY VLG #50 SW 34-124-64 1978 HOLY PARK NIEMAN, AUDREY J & CLINTON  
\$338.89 BOLS COUNTRY VLG #53 SW 34-124-64 1994 HIGHLAND RUSH, DOUGLAS V & ELIZABETH  
\$575.80 BOLS COUNTRY VLG #58 SW 34-124-64 2000 FRIENDSHIP 16X80 MY0022416V (MH) VAN HEERDE, BRENDA  
\$470.03 BOLS COUNTRY VLG #64 SW 34-124-64 1998 FRIENDSHIP 16X80 MY9819473V (MH) MARTINMAAS, JENNIFER  
\$320.31 BOLS COUNTRY VLG #75 SW 34-124-64 1994 FRIENDSHIP 28X70 MY-9412712ABV (MH) HAGEN, RON D  
\$542.01 BOLS COUNTRY VLG #87 SW 34-124-64 2000 PATRIOT KOLB, LANCE  
\$504.50 BOLS COUNTRY VLG #90 SW 34-124-64 2000 FRIENDSHIP 16X80 MY0022109V (MH) WAGEMAN, DARWIN & LOIS  
\$467.90 BOLS COUNTRY VLG #137 SW 34-124-64 2000 FRIENDSHIP NORDYKE, RALPH

\$22.34 BOLS OUTLOT P HECLA VLG 1985 MODULINE DANIELS, MARK & KAREN  
\$119.89 BOLS LT 5-6 BK 6 OP CLARMENT 1983 SCHULT SMITH, JEREMY & MELISSA  
\$446.29 BOLS MEINTS OL 1 N2 SE 20-125-62 1994 HIGHLAND 16X80 HI4575 CROSSAN, KIM & BONZOR, PAULA  
\$10.03 BOLS SE 8-125-63 EX W 55 A 1985 FRIENDSHIP PODOLL, JASON P  
\$56.34 BOLS S2 SE 30-124-61 (BIN) PRAY, CHAD  
\$174.76 BOLS LT 6 BK 6 WESTPORT 1986 MEDALLION STORM, KELLY D  
\$155.93 BOLS LOTS 17-19 BK 11 1982 ROLLOHOME WILSON, MICHAEL D.  
Published once at the approximate cost of \$671.03. (11751)

#### Groton City 2016 Salary Ordinance

ORDINANCE NO. 701  
An Ordinance entitled "The 2016 Salary Ordinance" to amend Ordinance No. 699 and Section 7.11 of the Groton Personnel Manual. Ordinance No 699, being an ordinance regulating the salaries of the elective and appointive officers and employees of the City of Groton and Section 7.11, an ordinance defining holidays.  
BE IT ORDAINED BY The City Council of the City of Groton that the 2016 salaries and time of payment are as follows for the elected and appointed officers and employees:  
Mayor- 400.00/month- Monthly; Council Members- 1,200.00/year- Annually +30.00/special evening City Council meeting- Monthly; Board of Equalization- 100.00/year- Annually; Planning & Zoning Commission -25.00/meeting- Monthly; Finance Officer- 5,439.20/month- Semimonthly; Deputy Finance Officer- 19.97/hour- Biweekly; Assistant Finance Officer & Police Sec- 19.54/hour- Biweekly; Public Works Coordinator & Street & Water Supt- 27.10/hour- Biweekly; Wastewater Supt- 23.89/hour- Biweekly; Asst Street Supt- 21.96/hour- Biweekly; Technology Specialist- 23.30/hour-Biweekly; Public Works Laborer-Part-Time- 15.80/hour- Biweekly; Electric Supt- 35.70/hour- Biweekly; Electric Lineman- 30.60/hour- Biweekly; Police Chief- 4,826.64/month- Semimonthly; Police Officer & Asst. Chief-4,324.32/month - Semimonthly; Police Officer Level 1-4,156.88/month - Semimonthly; Police Officer Level 2-3,661.84/month - Semimonthly  
Elective officials will receive \$100.00 per full day and expenses and \$25.00 per evening and expenses for attending other meetings and events which are not City Council meetings and are authorized. All changes in elected officials salaries will be effective after May 1, 2016.  
And Section 7.11 shall read: Holidays. The City of Groton recognizes and observes the following as paid holidays for eligible employees:  
New Years Day - January 1  
Presidents Day - 3rd Monday in February  
Memorial Day - Last Monday in May  
Independence Day - July 4  
Labor Day -1st Monday in September  
Pioneer Day - 2nd Monday of October  
Veteran's Day - November 11  
Thanksgiving Day - 4th Thursday in November & the following Friday  
Christmas Eve Day Afternoon - December 24 (1/2 Day)  
Christmas Day - December 25  
And all other days proclaimed as legal holidays by the Mayor of Groton.  
When a holiday falls on a Saturday, the preceding Friday is observed as the paid holiday for eligible city employees. If a holiday falls on a Sunday, it is observed on the following Monday. Police department employees are ineligible for these paid holidays, but will be granted ten and one half additional days of vacation leave which may be paid as the holiday occurs. Other employees ineligible for paid holiday leave will be granted a day off without pay in observance of a holiday.  
Passed First Reading 11/16/15  
Passed Second Reading 12/7/15  
Published 12/16/15  
Effective 1/1/16  
Scott Hanlon, Mayor  
Attest:  
Anita Lowary, Finance Officer  
Published once at the approximate cost of \$20.45. (11752)

#### Brown County Budget Supplement

NOTICE OF HEARING  
2015 BROWN COUNTY BUDGET SUPPLEMENT  
A public hearing will be held by the Brown County Commission on the 29th day of December 2015 beginning at 9:00 a.m. in the Brown County Commission Chambers, Courthouse Annex, Aberdeen, SD to consider supplementing the 2015 fiscal year budget, as follows: Brown County Fair Sponsorships #101-5.524.426.80 @ \$40,000.00, to be funded by sponsorships received #101-4.345.53 @ \$40,000.00; Brown County Fair Entertainment #101-5.524.422.73 @ \$60,000.00; Court Appointed Attorney #101-5.153.422 @ \$170,000.00; Maintenance #101-5.161.425 @ \$170,000.00, to be funded by undesignated surplus cash in the General Fund #101-5.101.99 @ \$400,000.00. The public is invited to attend the hearing and to present comments and testimony regarding the supplements.  
ATTEST:  
Maxine Fischer, Brown County Auditor  
(215.1222)  
Published twice at the total approximate cost of \$19.77. (11753)

#### Summons Jack Dixon Estate

STATE OF SOUTH DAKOTA IN CIRCUIT COURT  
COUNTY OF BROWN FIFTH JUDICIAL CIRCUIT  
\*\*\*\*\*  
\*\*\*\*\*  
\*\*\*\*\*  
In the Matter of the Estate of Jack Dixon  
Deceased Plaintiff  
VS  
Brown County, South Dakota; Home Federal Savings Bank, Sioux Falls, South Dakota; Accounts Management Inc., Sioux Falls, South Dakota, City of Groton, South Dakota; GGNSC Groton LLC d/b/a Golden Living Center, Groton South Dakota; South Dakota Department of Social Services; and all persons who have or claim to have, or who appear of record to have any interest or estate in, claim to, or lien or encumbrance upon the premises described in the summons and complaint, or any part thereof, or if deceased, their heirs, devisees, legatees, executors, administrators, or creditors, known or unknown, or any or either of them, and all persons unknown who may have or claim to have any estate or interest in or lien or encumbrance upon such real property or any part thereof.  
06CIV. 015 -000411  
SUMMONS  
Defendants  
\*\*\*\*\*  
\*\*\*\*\*  
\*\*\*\*\*  
TO THE STATE OF SOUTH DAKOTA, TO THE ABOVE NAMED DEFENDANTS:  
You are hereby summoned and required to answer the complaint of the plaintiffs which was filed in the office of the clerk of this Court at Aberdeen, Brown County, South Dakota, which complaint prays for a judgment vesting title in and quieting title to, and the determination of all adverse claims against the real property described in the complaint which is located in Brown County, South Dakota, to wit:  
Lots Thirteen (13), Fourteen (14), and Fifteen (15), Block Seven (7), Original Plat to Groton, according to the plat thereof of record, Brown County, South Dakota  
and to serve a copy of your answer to the complaint upon the undersigned at his office at Groton, South Dakota, within thirty days after the service of this summons upon you exclusive of the day of such service; if you fail to answer said complaint within the time period provided, the plaintiff will apply to the Court for a judgment by default which may be rendered against you for the relief demanded in the complaint.  
Dated this 25th day of September, 2015.  
KOLKER LAW OFFICE  
/r/ Richard Kolker  
Richard Kolker, Attorney for Plaintiffs  
P.O. Box 467  
102 North Main Street  
Groton SD 57445 (605) 397-8464  
(1124.1215)  
Published for four weeks at the approximate cost of \$90.99. (11675)

**Brown County  
Dec. 8, 2015  
Meeting Minutes**

DECEMBER 8, 2015 – GENERAL MEETING

Meeting called to order by Chairman Sutton at 8:45 A.M. in the Commissioner's Chambers, Courthouse Annex, Brown County, SD. Present were Commissioners Hansen, Kippley, Fischbach and Fjeldheim. Commissioner Hansen led the Pledge of Allegiance.

**MINUTES:** Moved by Fjeldheim, seconded by Fischbach to approve the Joint City/County Meeting Minutes and General Meeting Minutes of December 1, 2015. All members present voting aye. Motion carried.

**CLAIMS:** Moved by Hansen, seconded by Kippley to approve the following claims:

Professional Fees: Avera Sacred Heart Hospital \$1,722.34; Billie Ronshaugen \$49.40; Kristi Brandt \$421.00; Bridgeway Counseling Center \$3,200.00; Denise Cody \$21.00; Den Herder Law Office \$144.00; Fox & Youngberg \$180.00; William Gerdes \$16,470.00; Hennepin Co. Sheriff's Office \$70.00; HGG Architects \$13,363.80; Mark Katterhagen \$6.00; Kayla Cavalier \$35.96; LBG \$1,540.00; Lucy Lewno \$333.00; Midstates Printing \$75.00; Pollard Law \$180.00; Richardson, Wyly, Wise, Sauck \$3,890.10; Sanford Health \$3,876.37; SD Dept. of Revenue & Regulation \$590,788.97; Tammy Stolle Court Reporting \$189.20; Jodi Sudweeks \$98.60; Karen Swanda \$15.00; Thurman Law \$342.00; Woods, Fuller, Schultz & Smith \$539.50; Yankton Co. Sheriff \$125.00.

Publishing: American News \$533.90.

Rentals: Leroy Imberi \$300.00.

Repairs & Maintenance:

DFP \$8.00; Dakota Tree Co. \$1,730.00; Double D Body Shop \$181.75; Eiler's \$200.00; Great Western Tire \$13.00; House of Glass \$77.76; Lawson Products \$62.52; Lien Transportation \$1,686.25; Millborn Seeds \$17,121.38; Oasis Inn \$4.00; Pierson-Ford \$486.14; Sheehan Mack \$5,563.35; Zastrow's Sales & Service \$150.00.

Supplies: 3D Specialties \$4,563.00; A & B Business \$290.22; Ameripride Services \$213.36; Bakken Building Maint. \$500.00; Bonnie Bitz \$144.00; CarQuest \$1,276.59; Cartney Bearing \$131.58; Century Business Products \$163.74; Creative Product Source \$471.73; Crescent Electric \$13.18; DFP \$427.68; Den Herder Law Office \$10.48; Earthgrains \$734.05; Farnam's \$21.34; Fastenal \$474.41; Fox & Youngberg \$7.32; Galls \$98.01; GovConnection \$615.48; Great Western Tire \$7,159.31; Hanten's Repair \$38.31; Hecla Implement \$8.25; IDC \$37.89; Interstate Battery \$375.80; J. Gross Equipment \$754.80; Lawson Products \$841.48; Leidholdt Tool Sales \$4.26; Lucy Lewno \$11.74; Marco \$473.83; Midstates Printing \$188.88; Midwest Card & ID Solutions \$1,500.00; NCFE - Warner \$5,946.26; Network Services \$1,281.73; Pitney Bowes \$126.00; Pizza Ranch \$111.43; Pollard Law \$3.00; Rowman & Littlefield Publishing \$78.00; Running's \$484.48; Schaeffer's Mfg \$483.04; Sciencecenter \$10,000.00; Christy Serr \$5.26; Sewing Shoppe \$27.00; Taylor Laundry \$112.00; Thurman Law \$6.78; Tyler Business Forms \$435.52; Ultramax \$906.00; Web Water Bottling Co. \$6.50; Zastrow's Sales & Service \$74.53.

Travel and Conference: Exec. Mgmt. \$1,552.00; Mark Milbrandt \$304.00; Oasis Inn

\$110.00; Sanford Health Occupational \$70.00.

**Utilities:** Aberdeen City Treasurer \$1,143.35; AT & T \$69.99; BDM Rural Water \$30.00; CenturyLink \$258.17; Exec. Mgmt. \$98.64; Midcontinent \$410.60; Northern Electric \$56.04; NVC \$2,879.29; NWPS \$10,386.29; Town of Frederick \$41.00.

**Other:** Safe Harbor \$842.00; SDACO \$1,088.00. All members present voting aye. Motion carried.

**NECOG AGREEMENT:** Moved by Fischbach, seconded by Fjeldheim to approve and authorize the Chairman sign Joint Cooperative Agreement with NECOG for 2016 in amount of \$23,560.43. All members present voting aye. Motion carried.

**BCCHC CONTRACT:** Moved by Fjeldheim, seconded by Kippley to approve and authorize the Chairman sign Contract with the State of South Dakota for providing community health-nursing services in Brown County for fiscal year 2016 in amount of \$18,540.00. All members present voting aye. Motion carried.

**BUDGET SUPPLEMENT 2015:** Moved by Fjeldheim, seconded by Hansen to authorize public hearing to be held on the 29th day of December, 2015 beginning at 9:00 a.m. in the Brown County Commission Chambers, Courthouse Annex, Aberdeen, SD to consider supplementing the 2015 fiscal year budget, as follows: Brown County Fair Sponsorships #101-5.524.426.80 @ \$40,000.00, to be funded by sponsorships received #101-4.345.53 @ \$40,000.00. Brown County Fair Entertainment #101-5.524.422.73 @ \$60,000.00; Court Appointed Attorney #101-5.153.422 @ \$170,000.00; Maintenance #101-5.161.425 @ \$170,000.00, to be funded by undesignated surplus cash in the General Fund #101-1.101.99 @ \$400,000.00. All members present voting aye. Motion carried.

**INCREASE SPENDING AUTHORITY/ESTIMATED REVENUE:** Moved by Fischbach, seconded by Kippley to increase spending authority and estimated revenue in the following funds for unanticipated reimbursement for expenditures: Fund #101-4.339 @ \$13,820.98, #101-5.120.411 @ \$511.72, #101-5.120.422 @ \$6,615.00, #101-5.120.423 @ \$2,493.32, #101-5.120.426 @ \$2,794.74, #101-5.120.427 @ \$10.20, #101-120.425.03 @ \$1,396.00 (Elections); Fund #101-4.331.97 @ \$53,324.72, #101-5.152.411 @ \$44,974.32, #101-5.152.426 @ \$4,274.08, #101-5.152.427 @ \$2,106.02, #101-5.152.412.10 @ \$1,970.30 (SVAWA Grant); Fund #226-4.331.23 @ \$21,445.07, #226-5.228.426.69 @ \$21,445.07 (HLS Grant). All members present voting aye. Motion carried.

**OPERATING TRANSFERS:** Moved by Fischbach, seconded by Fjeldheim to approve and authorize the following operating transfer from the General Fund #101-911-191 in total amount of \$1,000,000.00 to Road and Bridge Fund #201-371 @ \$1,000,000.00, as reflected in the 2015 General Fund Budget. All members present voting aye. Motion carried.

**WAIVE FEE:** Moved by Fischbach, seconded by Kippley to waive penalty and interest fee in amount of \$18.02 on real estate taxes, as notification sent to wrong person. All members present voting aye. Motion carried.

**BID AWARD SCBA TANKS:** Moved by Hansen, seconded Kippley to purchase an additional 36 SCBA (Self Contained Breathing Apparatus) Tanks for the Brown County Rural Fire Chiefs from the bid awarded by Brown County on December 30, 2014 to Allegiant Emergency Services Inc in amount of \$36,000.00, to be funded in 2016 by Homeland Security Grant Funds. All members present voting aye. Motion carried.

**FINANCIAL REPORT STAN-**

**DARDS:** Commissioner Kippley offered the following Resolution: RESOLUTION #85-15. WHEREAS, the Governmental Accounting Standards Board (GASB), a not-for-profit national organization issued statement of Governmental Accounting Standard No. 34 - Basic Financial Statements - and Management's Discussion Analysis, and WHEREAS, both the GAAP (modified accrual basis) and the Special Purpose Reporting (modified cash basis) entities follow these standards, and WHEREAS, Brown County has been following the GAAP standards since implementation of GASB 34, and WHEREAS, it has been determined that most South Dakota Counties use the Special Purpose Reporting (modified cash basis) standards and find them just as effective as the GAAP standards, and WHEREAS, GASB requires that policies are established for long-term investments, capital assets, interest earnings, and restricted and unrestricted resources. NOW, THEREFORE BE IT RESOLVED that Brown County's financial statements will be prepared on Special Purpose Reporting Standards, the modified cash receipts and disbursement basis of accounting (GASB 34 "modified cash basis"), and FURTHER BE IT RESOLVED that the following policies be restated to accompany the Special Purpose Reporting (modified cash basis) method of accounting: (1) Long-Term Investments acquired with cash assets will be recorded at cost. 2) Capital Asset Capitalization Policy: a) Land and Land Rights - all purchases included. b) Buildings - \$25,000. c) Improvements other than buildings - \$25,000. d) Machinery and Equipment - \$5,000. e) Infrastructure - \$25,000. f) Bridges - Structures greater than 20' (SDCL 31-14). f) Roads - composite method: entire system including base, culverts and gravel surface. g) Paved Road New Construction - composite method, with definition of new construction being 2" overlay or greater for distance exceeding one mile. h) Personal Property Listings - All county departments are required to file an additional personal property list, to be used for tracking items with an original cost of less than \$5,000 for purposes of theft and/or disaster recovery and insurance coverage. 3) Interest earnings will be recorded in the respective county funds applicable. 4) Restricted and Unrestricted Resource Policy: When both restricted and unrestricted resources are available for use, it is the policy of Brown County to use restricted resources first, then unrestricted resources as they are needed. AND FURTHER RESOLVE that Brown County chooses not to prepare the optional Management's Discussion Analysis. Dated this 8th day of December 2015

Seconded by Commissioner Hansen. Roll call vote: Commissioners Hansen-aye, Kippley-aye, Fischbach-aye, Fjeldheim-aye, Sutton-aye. Resolution adopted.

**AUDITORS REPORT OF ACCOUNT:** Moved by Fjeldheim, seconded by Fischbach to approve the November 2015 Auditor's Report of Account with the County Treasurer in total amount of \$22,118,809.56 (total amount of actual cash @ \$3,800.00, US Bank @ \$27,638.02, Dacotah Bank @ \$667,644.71, Petty Cash @ \$2,000.00, Fund Investments @ \$21,417,726.83). All members present voting aye. Motion carried.

**BID AWARD - SHERIFF VEHICLES:** Moved by Hansen, seconded by Fjeldheim to award the following bids for the Sheriff Department: State Contract #16866 from Billion Motors for (1) one Chevrolet Tahoe in amount of \$34,948.00 and State Contract #16870 from Pierson Ford for (2) two Ford Interceptor SUV's in amount of \$56,870.00. All members present voting aye. Motion carried.

**GUARDRAIL ON BR351:** Moved by Hansen, seconded by Kippley to approve and authorize the Chairman sign Utilities Certificate for Project #P6525(03) PCN 04Q0 (Guardrail project on

BR351). All members present voting aye. Motion carried.

**BROWN COUNTY TRANSPORTATION PLAN CERTIFICATION:** Moved by Kippley, seconded by Fischbach to approve and authorize the Chairman sign Brown County Transportation Plan Certification for the SDDOT. All members present voting aye. Motion carried.

**BID AWARD SEMI TRACTOR:** Time and place, as advertised to open, read and consider sealed bids for furnishing and delivery of one (1) new 2017 Tandem Axle Semi Tractor for the Highway Department. Bids were received from Sheehan Mack Sales and Crawford Trucks. Moved by Hansen, seconded by Fjeldheim to refer all bids to Dirk Rogers, Highway Superintendent for review and recommendation. All members present voting aye. Motion carried.

**BID -BR 218 ON CO RD 5:** Time and place, as advertised to open, read and consider sealed bids for the 2016 County Road 5 - Bridge #218 Replacement Project. Bids were received from Duinick Inc, Prinsburg MN; Industrial Builders Inc, Fargo ND; Grangaard Construction, Watertown SD. Moved by Fjeldheim, seconded by Fischbach to refer all bids to Dirk Rogers, Highway Superintendent for review and recommendation. All members present voting aye. Motion carried.

**EQUIPMENT PURCHASE:** Moved by Hansen, seconded by Fischbach to approve purchase of a Kyocera TASKalfa 3051ci Color MFP for the Director of Equalization Department in amount of \$6,648.04 from Century Business Products. All members present voting aye. Motion carried.

**EXECUTIVE SESSION:** Moved by Hansen, seconded by Kippley to go into executive session for personnel discussion, per SDCL 1-25-2(1) with Larry Lovrien, Gary Vetter and Derek Ricci in attendance. All members present voting aye. Motion carried. The Chairman declared the executive session closed, with no action taken as a result of the discussion.

**COUNTY ROAD 9:** Dale Kurth, Ron Wegleitner and Justin Wegleitner met to question the possibilities of opening the section of County Road 9 east of the curve entering Claremont. No official action was taken.

**CLOSING AUDIT CONFERENCE:** Russ Olson, Audit Manager for the Department of Legislative Audits met with the Commission for closing conference for audit of fiscal year 2014.

**TACOMA PARK:** Area resident George Nikolas met to discuss and present historical information in regard to the roads, bridges and dam at Tacoma Park. Bill Antonides was also in attendance. No official action was taken.

**US HIGHWAY 12:** Commissioner Fischbach offered the following Resolution: RESOLUTION #86-15. RESOLUTION EXPRESSING SUPPORT OF U.S. HIGHWAY 12 EXPANSION TO 4 LANES. WHEREAS, in South Dakota, U.S. Highway 12 is a two-lane highway for approximately twenty-one (21) miles between Aberdeen, South Dakota and Ipswich, South Dakota; and WHEREAS, there have been numerous fatal wrecks on U.S. Highway 12 between Aberdeen, Ipswich and Mobridge; and WHEREAS, it is urged that changes be made on U.S. Highway 12 due to 8 fatalities in 2015 alone; and WHEREAS, in 2014 traffic counts in the 2-lane stretch between Aberdeen and Ipswich were 3660, 4010 and 3040 vehicles respectively on the 3 segments going west; and WHEREAS, the 3660 vehicle segment in Brown County is projected to be 5409 vehicles by 2030 per transportation plan study compiled in 2012; and .. WHEREAS, the potential almost forty-eight percent (48%) traffic count increase in the next 15 years is further cause for concern; NOW, THEREFORE, the Brown County Commission does hereby adopt, in its entirety, this resolution to urge State officials to provide adequate funding for this important project to expand such portion of highway at minimum from Aberdeen to Ipswich from two lane to four lane; and does direct its administrator to prepare and furnish a copy of this Resolution for submission to the Governor, South Dakota Congressional delegation and South Dakota Department of Transportation. Adopted this 8th day of December 2015. Seconded by Commissioner

Hansen. Roll call vote: Commissioners Hansen-aye, Kippley-aye, Fischbach-aye, Fjeldheim-aye, Sutton-aye. Resolution adopted.

**EXECUTIVE SESSION:** Moved by Fjeldheim, seconded by Hansen to go into executive session for personnel discussion, per SDCL 1-25-2(1) with Larry Lovrien and Gary Vetter in attendance. All members present voting aye. Motion carried. The Chairman declared the executive session closed, with no action taken as a result of the discussion.

**ADJOURNMENT:** Moved by Fjeldheim, seconded by Kippley to adjourn the Brown County Commission. All members present voting aye. Motion carried.

**Maxine Fischer, Brown County Auditor**  
Published once at the total approximate cost of \$132.32. (11754)

**Westport Town  
Dec. 7, 2015  
Meeting Minutes**  
Town of Westport General Meeting  
December 7th, 2015  
The Town of Westport met on December 7th, 2015 with John Bain, Jan Ellefson, Doreen Hertel, Mike Wilson and 9 community members present.  
The following expenses were presented:  
City General  
NWPS (\$301.64), Postmaster (\$2.52 & 2.96) SD municipal league-membership (\$144.81), Midstates Printing (\$2.75), Mavericks (\$100.00), Allied Insurance (\$3249.00), Groton Independent (\$61.97) Payroll - John Bain (\$75.00), Jan Ellefson (\$75.00), Mike Wilson (\$75.00) & Doreen Hertel (\$365.90).  
Sewer  
NWPS (\$66.78), NRWA -loan repayment (\$210.13), Dakota Pump & Control (\$1,345.62), SD-DENR (\$50.00), Payroll - Doreen Hertel (\$120.00).  
Water  
WEB (\$989.54), Dept. of Revenue (\$15.00), Water Maintenance District (\$321.43), Clark Engineering (\$1,805.17), Royane & Cogley (\$ 159.00), Meierhenry Sargent (\$1,000.00), Roto Rooter (\$252.00), Payroll - Doreen Hertel (\$240.00).  
Jan Ellefson made motion to pay all bills; second by John Bain.  
The following deposits were presented:  
City General  
Brown County Collections (\$4,037.71), Brown County Treasurer (\$50.00), State of SD (\$4,711.55), Building Permit (\$40.00), Interest (\$14.93).  
Sewer  
Resident Payments - (\$1,705.00), Brown Co Collections (\$3,188.99).  
Water  
Resident Payments - (\$2,402.00).  
NEW BUSINESS:  
A request, by a resident, to annex an alley behind his residence was denied.  
The lift station has needed repair work in the last month. There seems to be an excess of grease build up. The city is asking residents not to pour grease down the drain. Mike Wilson will be cleaning up the lift station on a monthly basis to keep the floats clean of that grease.  
The new water rates were discussed and will go into effect once all of the new water meters have been replaced. The new base will be \$45.00 and the per gallon rate will be \$3.75 and overage gallons will be \$5.50.  
The wooden playground equipment will be torn down as it is no longer safe to play on. The city will look at other ways to replace the play area. A pancake fundraiser was suggested.  
The city is in the process of starting a waste water project. There are 3 major projects that need attention. 1st is replacement of lift station with an estimate cost of \$244,000. 2nd Storm sewer with an estimate cost of \$354,910. And 3rd the Rip Rap around lagoon with the cost of \$209,000. Ted Dickey from NECOG will be in Westport on December 29th to discuss this project and possibility of a grant.  
Each water meter will be inspected at time of removal. If there is a large discrepancy with what had been reported and what the meter is reading, that finding will be reported to the board. Then the board will review that finding and many charge a penalty for fraudulent reporting of \$250.  
Doreen Hertel, Finance Officer  
Published once at the total approximate cost of \$27.63. (11755)

**2016 DOG LICENSES AVAILABLE NOW!!**  
Licenses due by Dec. 31, 2015  
Fines start after Dec. 31, 2015  
Dogs CAN NOT be licensed without providing updated rabies shot information, please bring records for each dog to City Hall  
Please contact City Hall as soon as possible if you no longer have any dogs  
Spayed or neutered dogs are \$5 per dog, otherwise \$10 per dog

**Be the match for Madison**

Madison Central School District is seeking a strong educational leader to be Superintendent of Schools.

**Candidates should possess:**

- High standards of ethics, honesty and integrity.
- Ability to work effectively with others.
- Effective communication skills.
- Drive to improve and shared decision making.
- Commitment to student welfare and achievement.
- Ability to develop plans, goals, and expectations.
- Regard for employee relations.



For more information, contact Dr. Randy Royer with ASBSD at rroyer@asbsd.org or 605-773-2504.

**HEALTH INSURANCE INSIGHT #23**

**NOT ALL PLANS ARE THE SAME**

With the backing of a trusted health care system, Avera Health Plans can provide both coordinated care and better rates.

**Bonus savings:** Your family size and income may qualify you for lower monthly payments.

COMPARE AND SAVE ON A PLAN.

Call us at 605-988-8491 or talk to your local agent.



**TAKING APPLICATIONS FOR ALL SHIFTS/POSITIONS!**

Competitive benefits package & Competitive Wages!

Apply in person at 515 Noid Road, Canton, SD 57013. Call Mary with questions at 605-764-4043. FOR OUR CANTON, SD LOCATION!



# Columbia Insurance Agency

Marty Weismantel, Agent

Columbia ~ 605/396-2341

**"Your Home Owned Independent Agency"**



Put Us To Work For You!  
We're a tight family team.  
Everybody works hard  
& does their fair share.  
(605) 395-6981  
14320 408th Avenue  
Groton, SD 57445  
www.tuffernhell.com

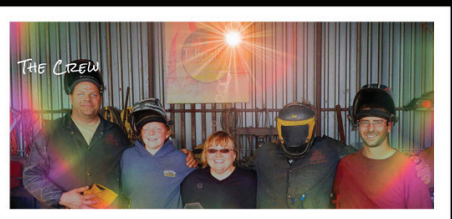

## Girls go to 2-0 with win over Titans



**Groton's Carly Wheeting and Emily Locke and Leola-Frederick's MiKayla Forsting battle for the loose ball.**



**Carly Wheeting tries to put up this shot with April Hoffman (3) and MacKenzie Heilman (21) double teaming her.**



**Jessica Bjerke going for the shot.**



**MacKenzie Heilman, Michaela Podoll and April Hoffman bring the ball upcourt.**

Groton Area fended off rallies by Leola-Frederick in girls basketball action played Saturday in Groton. The Tigers jumped ahead in the fourth quarter and went on for a 47-41 non-conference win. Groton Area is now 2-0 on the season and travel to Tiospa Zina on Monday. This was Leola-Frederick's first game of the season and will travel to Aberdeen Christian on Thursday.

Groton Area jumped out to a 12-5 lead and the margin evaporated to two points by the end of the first quarter, 15-13. Leola-Frederick tied the game at 15 and took an 18-15 lead. Miranda Hanson hit a three-pointer to tie the game at 18. The Titans tied the game at 20 and took a 24-20 lead, but Groton Area scored

the last five points of the first half to take a 25-24 lead at halftime. The game was tied at 30 in the third quarter as Groton Area took a 36-32 lead going into the fourth quarter. The Titans tied the game at 41 in the fourth quarter, but the Tigers scored the last six points of

the game to secure the win.

Audrey Wanner did not play for the Tigers as she suffered a sprained ankle in the fourth quarter of the Ipswich game, but she will be returning to the court against Tiospa Zina. Harleigh Stange led the Tigers in scoring with 17 points followed by Carly Wheeting with 11, Jessica Bjerke added 11, Miranda Hanson came off the bench to hit two three-pointers for six points, Katie Koehler had three points and Gia Gengerke added two points. Stange had three three-pointers and Koehler had one.

MacKenzie Heilman led the Titans with 12 points followed by April Hoffman with 10, Abby Berreth had five and Cassandra Hinz and Michaela Podoll each had three. Heilman had two three-pointers and Hinz had one.

Leola-Frederick made 34 percent of its two-pointers, 25 percent of its three-pointers and was eight of 13

from the line off of Groton Area's 15 team fouls. The Titans had 21 rebounds, 10 turnovers, five steals and eight assists. Hoffman had nine rebounds and Podoll had six assists.

Groton Area made 48 percent of its field goals, 40 percent of its three-pointers, and was one of 11 from the line off of Leola-Frederick's 19 team fouls. The Tigers had 35 rebounds with Wheeting having 16 and Bjerke 10. Stange had six of the team's 12 assists and three of the team's six steals. Wheeting had two blocks and the team had 17 turnovers. There was no junior varsity game.

## Groton boys win season opener over Titans



**Leola-Frederick's Jordan Haas passes the ball to Logan Heupel.**



**Sean Schuring playing defense on Titans' Alex Sumpston.**



**Hunter Lerew going for the shot under the basket.**



**Bennett Shabazz goes for a three-point shot.**

The Groton Area boys' basketball team opened its season Saturday with an 81-40 non-conference win over Leola-Frederick. The game was played at the Groton Arena. The Tigers will host Hitchcock-Tulare on Tuesday while Leola-Frederick will travel to Langford Area on Tuesday.

Groton Area jumped out to a 17-0 lead and took a 23-2 lead at the end of the first quarter. The Tigers led at half time, 44-19, and at the end of the third quarter, it was 64-29.

Three players hit double figures for the Tigers with Seric Shabazz leading the way with 21 points followed by Bennett Shabazz and Sean Schuring with 14 each, Brandon Keith had nine, Aaron Severson eight, Adam Herman seven, Hunter Lerew six and Truitt Rogers added three points. The Titans were led by Steven Haas with 18 points followed by Logan



**Lance Feickert attempts this shot for the Titans.**

Heupel with 10, Jordan Haas had five, Lance Feickert four, Alex Sumpston three and Fred Lapka added two. Making three-pointers were Seric with four, Bennett and Keith each had two and Herman and Schuring each had one for Groton Area. The Titans had Steven with two and Alex and Jordan with one each.

Groton Area made 49 percent of its field goals, 40 percent of its three-pointers, and was nine of 16 from the line for 56 percent. Lerew had 10 of the team's 33 rebounds. Bennett Shabazz had five of the team's 14 assists and five of the team's 12 steals. Groton Area had 12 turnovers and had 19 team fouls. Hunter Lerew had two blocks and Herman had one.

The Titans made 30 percent of their two-pointers and 18 percent of their three-pointers and were 12 of 16 from the line for 75 percent. Heupel had eight of the team's 33 rebounds. Leola-Frederick had three assists, four steals and 22 turnovers.

**Aberdeen**  
Chrysler Center

901 Auto Plaza Drive  
Aberdeen, SD  
800.874.9173

www.aberdeenchrysler.com



Lance Frohling  
Groton Location Manager  
605-397-2671  
frohlingl@fullcircleag.com



## Toys And Joys of Christmas

Do you write to Santa Claus or visit him to tell him what you would like for Christmas? What is the special toy that *you* have your eye on?

Choo! Choooo! Trains run around the bottom of Christmas trees. Reindeer have red, blinking noses. Christmas toys can bring lots of joy, especially when shared with others.

Read the clues to fill in the crossword puzzle:

1. ice \_\_\_\_\_
2. \_\_\_\_\_ to Santa
3. \_\_\_\_\_ bell
4. gingerbread \_\_\_\_\_
5. tin \_\_\_\_\_
6. \_\_\_\_\_ over a fireplace
7. long wooden \_\_\_\_\_
8. Sugar Plum \_\_\_\_\_
9. Model \_\_\_\_\_ under the tree
10. \_\_\_\_\_ ballet
11. \_\_\_\_\_ on the shelf
12. holiday \_\_\_\_\_
13. \_\_\_\_\_ pull Santa's sleigh
14. \_\_\_\_\_ for naughty kids
15. striped candy \_\_\_\_\_

16. rocking hobby \_\_\_\_\_
17. steaming hot \_\_\_\_\_
18. \_\_\_\_\_ hat:  
red with white fur
19. crunchy \_\_\_\_\_ for reindeer
20. singing \_\_\_\_\_
21. \_\_\_\_\_ gliding downhill
22. Santa's \_\_\_\_\_

23. spinning \_\_\_\_\_
24. North \_\_\_\_\_
25. holiday drink, \_\_\_\_\_
26. Sugary \_\_\_\_\_ with fun shapes
27. \_\_\_\_\_, Santa's favorite drink
28. \_\_\_\_\_ cubes for the reindeer
29. \_\_\_\_\_ on the top of the tree
30. wind-up \_\_\_\_\_

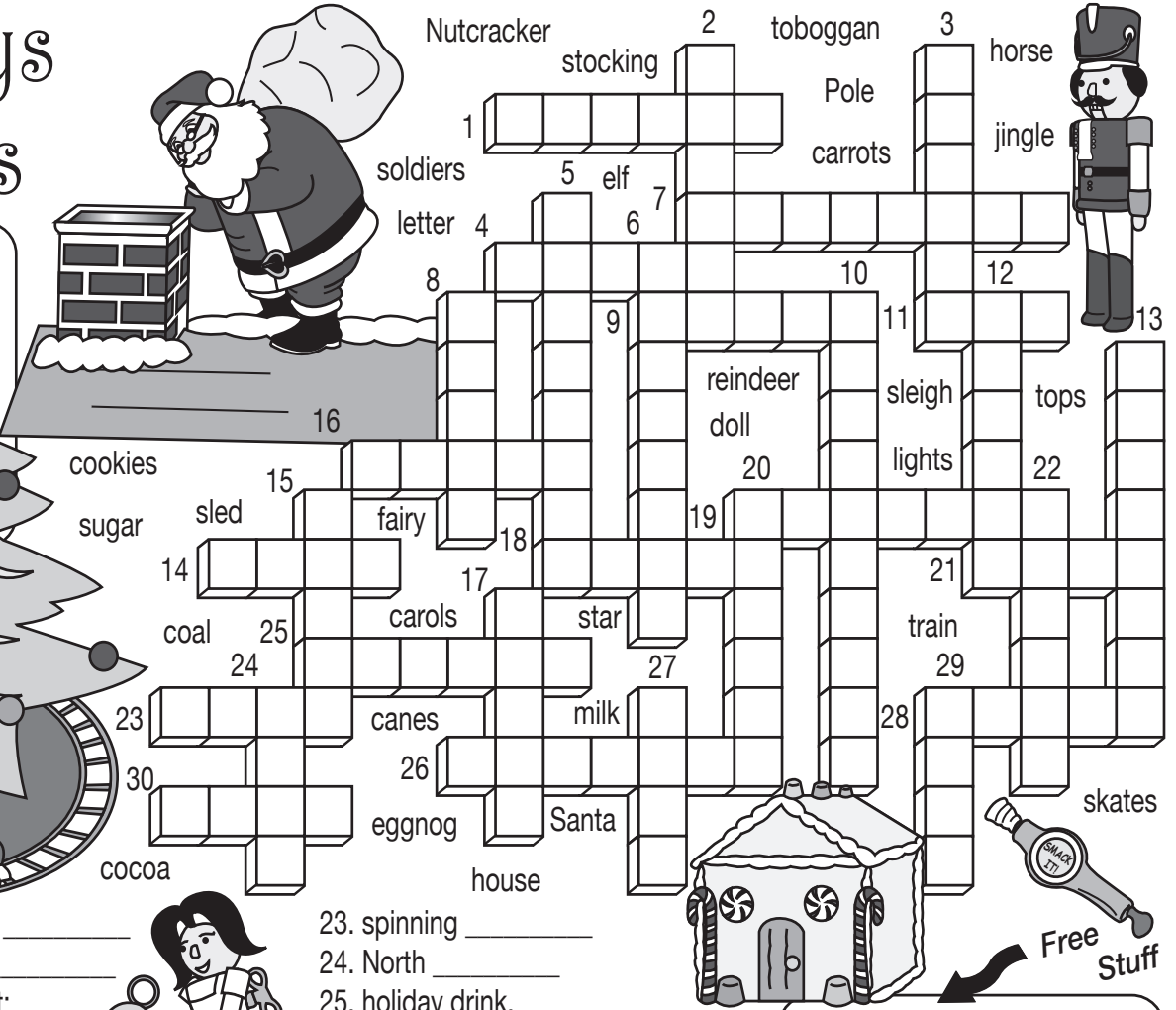

Fill in the blanks to spell the names of Santa's reindeer:

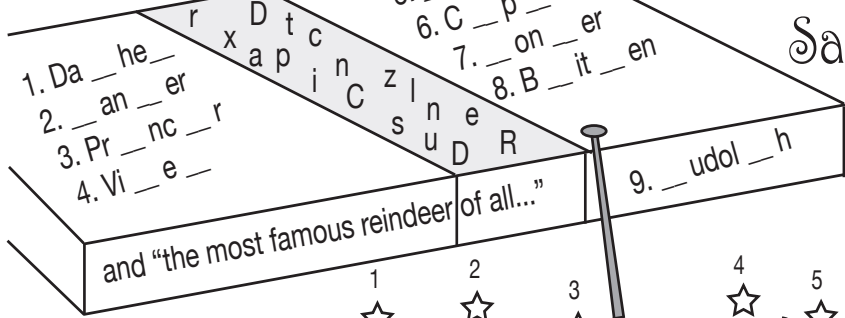

## A Present from Santa Claus

What did Santa leave under the tree? The box is open, now **follow the numbered stars to see!**

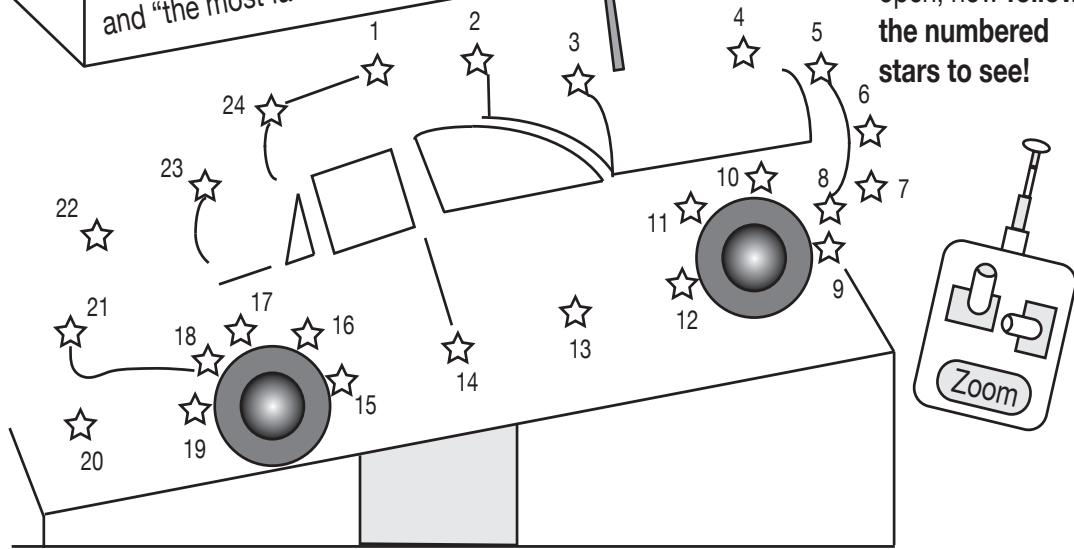

## Holiday Toys and Surprises

There are so many kinds of toys and surprises that might be found under the tree. Use the letter bank below and cross off the letters as you fill in the blanks:

1. ga \_ es and pu \_ zles
2. \_ olls and s \_ uffed ani \_ als
3. con \_ truction to \_ s
4. mo \_ els
5. spo \_ ts equi \_ ment
6. bik \_ s and ridi \_ g toys
7. ca \_ s and truc \_ s
8. trai \_ se \_ s
9. art \_ and cra \_ ts
10. musi \_ al instrume \_ ts

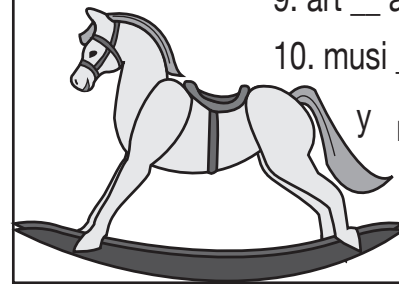

y m z r m n c  
s t p s n  
n d d k r

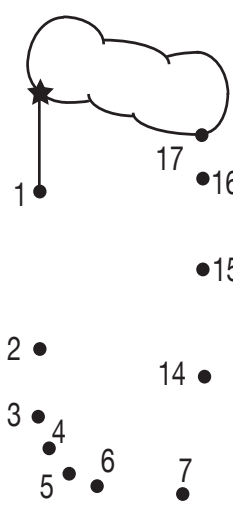
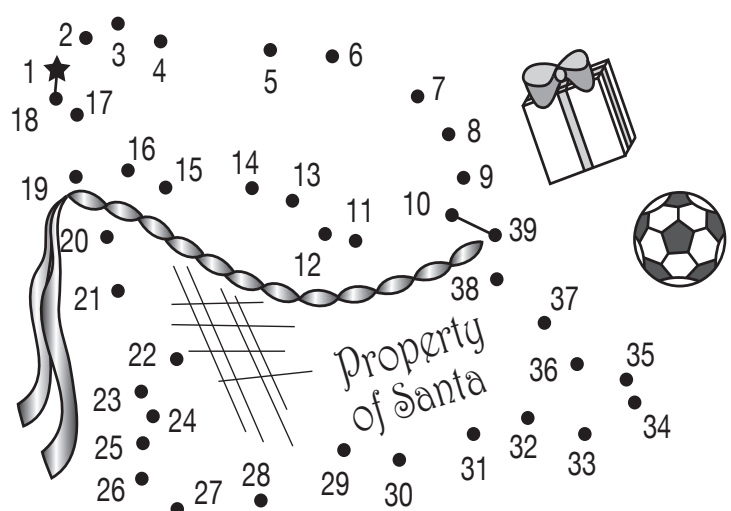

## Where Are The Toys?

Where might we find the toys? Follow the dots to see where the toys are packed, stuffed or left:

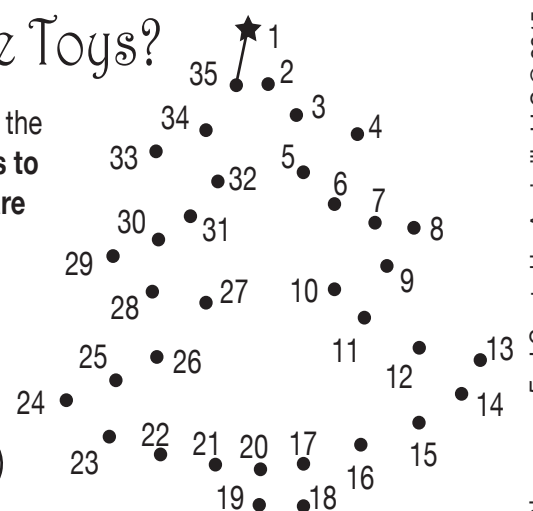



# Community Calendar

**GROTON VET CLINIC**  
1503 N Broadway, Groton, 605/397-8145

**Conde National**  
**Dec. 14 Team Standings:**  
Mets 28 1/2, Cubs 26, Giants 22, Pirates 21, Braves 18, Colts 15 1/2  
**Men's High Games:**  
Lance Frohling 234, 200; Topper Tastad 192, Bryce Dargatz 172, John Lowary 172  
**Men's High Series:** Lance Frohling 593, Bryce Dargatz 489, John Lowary 484  
**Women's High Games:**  
Vickie Kramp 178, Michelle Johnson 170, Mary Larson 162  
**Women's High Series:**  
Mary Larson 450, Vickie Kramp 443, Michelle Johnson 431, Alice Severson 431

**Cutler Family Hair Care**  
603 N 2nd St, Groton  
605/397-2629

**Wheat GROWERS**  
Connecting Solutions

**DACOTA BANK** Here for you.  
Member FDIC

**Ryan Likness Agency Inc.**  
American Family Insurance  
leaves carefully, dreams fearlessly.  
717 Main St., Britton • 448-2357  
702 Main St., Webster • 345-4880  
rlkness@gamfam.com

**POET** biorefining  
**Groton**  
397-2726

**RDO EQUIPMENT CO.**  
Aberdeen 225-6772 1-800-843-1865  
Redfield 1-800-247-4650  
Webster 1-800-658-2252

**Farmers Union CO-OP**  
101 S 1st Ave., Ferney  
395-6461

**Groton Transit Christmas Open House**  
December 18th  
9am to 4pm.  
**Register for Door Prizes**  
Come in for Cider, Coffee and goodies.  
All welcome!

**Wednesday, December 16**  
**School Breakfast:** Egg and cheese omelet, fruit, juice, milk.  
**School Lunch:** Soft shell tacos, refried beans, fruit.  
**Senior Menu:** Lasagna rotini, tossed salad with dressing, ambrosia fruit salad, oatmeal spice cookie, whole wheat bread.  
**Birthdays:** John Sippel • Layne Howard • Sage Mortenson • Dan Schinkel  
7:00am: United Methodist Men's Bible Study  
12:00pm: Kiwanis meets at the Community Center  
3:45pm: St. John's Lutheran Confirmation  
7:00pm: St. John's Lutheran Advent Service

**Thursday, December 17**  
**School Breakfast:** Breakfast pizza, fruit, juice, milk.  
**School Lunch:** Ham and cheese sandwich, fruit, French Fries, broccoli and dip.  
**Senior Menu:** Roast beef, potatoes, carrots and onions, gravy, peaches, multi-grain dinner roll.  
**Birthdays:** Tammy Locke, Breanna Marzahn, Alan Townsend  
9:00am: St. John's Lutheran Quilting  
7:00pm: MS/HS Christmas Concert at GHS Gym

**Friday, December 18**  
Debate at Brookings  
**School Breakfast:** Cinnamon roll, yogurt, fruit, juice, milk.  
**School Lunch:** Quesadilla, corn, mixed veggie trays, fruit.  
**Senior Menu:** Breaded codfish, parsley buttered potatoes, coleslaw, orange sherbet, whole wheat bread.  
**Birthdays:** Jean Harrison, Pastor Craig Grams, Jasper Pray, Kelly Pappas, Dylan Hanson, Michaela Oleson  
2:00pm: Elementary Christmas Concert at GHS Gym  
4:00pm: Basketball Double Header at Deuel (JV girls at 4:00, JV Boys at 5:00, C boys at 4:00, Girls JV at 4:00, Boys JV at 5:00, Girls Varsity at 6:30, Boys Varsity at 8:00)

**Saturday, December 19**  
Debate at Brookings  
**Birthdays:** Jeff Howard, Tim Thurston, Brad Waage, Gretchen Dinger, Quenton Severson  
10:00am: Emmanuel Lutheran Worship at Rosewood Court  
11:00am: NEC Wrestling at Milbank  
4:30pm: St. Elizabeth Ann Seton Catholic Church Mass

**Sunday, December 20**  
**Anniversary:** Lon & Marva Gellhaus  
**Birthdays:** • Virginia Spencer • Lisa Adler • Jim Pray • Harvey Flihs III • Lexi Osterman  
9:00am: Emmanuel Lutheran School  
9:00am: St. Elizabeth Ann Seton Catholic Church Mass  
9:00am: St. John's Lutheran Worship with Communion  
10:00am: Heaven Bound Ministries worship at Pier-

pont Church  
10:00am: St. John's Lutheran Christmas Program practice  
10:15am: Emmanuel Lutheran Christmas Program  
11:00am: United Methodist Church Worship  
3:00pm: 3:00 pm: Open Gym (JK-8th grade 6th grade - 12th grade 5=7 pm)  
3:30pm: Emmanuel Lutheran fellowship at Golden Living Center (confirmands serve)

**Monday, December 21**  
No School  
**Senior Menu:** Beef stroganoff noodles, mixed vegetables, cake with strawberries, whole wheat bread.  
**Birthdays:** Kent Webb, Kayla Townsend, Ashley Flihs, Steve Giedt, Eva Ellis, Gavin Englund, McKenna Tietz, Noella Graf  
6:30am: Emmanuel Lutheran Bible Study  
5:15pm: BBB host Roncalli (C game at 5:15, JV at 6:30, varsity at 8:00)  
7:00pm: City Council Meeting

**Tuesday, December 22**  
No School  
**Senior Menu:** Tater tot hot dish, green beans, grape juice, sour cream apple pie square, whole wheat bread.  
**Birthdays:** • Don Raines, Kristen Winther, Cameron Howard, Kelby Tracy  
10:00am: United Methodist Women's Bible Study  
3:30pm: BBB vs. Eureka/Bowdle at NSU Classic  
6:30pm: GBB at Roncalli

**Wednesday, December 23**  
No School  
**Senior Menu:** Turkey and dressing, mashed potatoes and gravy, broccoli, carrot bar.  
**Anniversaries:** Jerry & Joan Johnson, Jerry & Ramona Rossow, Marc & Fran Sippel  
**Birthday:** Diane Lewandowski, John Padfield  
7:00am: United Methodist Men's Bible Study  
12:00pm: Kiwanis meets at the Community Center  
6:30pm: St. John's Lutheran Christmas Program practice

**Groton Holiday Lighting Contest**  
Thursday, Dec. 17th

**Toys And Joys of Christmas**  
There are so many kinds of toys and surprises that might be found under the tree. What are your favorite kinds of toys? One that I really like is my plastic, wind-up, walking chunk of cheddar cheese!

**Holiday Toys and Surprises**

- games and puzzles
- dolls and stuffed animals
- construction toys
- models
- sports equipment
- bikes and riding toys
- cars and trucks
- train sets
- arts and crafts
- musical instruments

**MEYERS TRACTOR SALVAGE**  
ABERDEEN, SD

1000+ Salvaged Tractors & Combines  
400+ Reground Crankshafts  
500+ Tractor Tires  
300+ Rebuilt Radiators

Large Line of Swather, Baler & Cutter Parts.  
**GREAT BUYS & SERVICE!**

WANT TO BUY TRACTORS, COMBINES & SWATHERS FOR SALVAGE

Phone (605) 225-0185  
5 Miles North & 1 Mile West of CASE-IH

# Proposed 2016-17 Groton Area School Calendar

GROTON AREA SCHOOL DISTRICT  
2016-2017  
SCHOOL CALENDAR  
Amended Draft 12/7/15

DRAFT A.2

## AUGUST

S	M	T	W	T	F	S
	1	2	3	4	5	6
7	8	9	10	11	12	13
14	15	16	17	18	19	20
21	22	23	24	25	26	27
28	29	30	31			

August 23 - Faculty Inservice  
23 - Welcome Back Picnic (5:00 PM)  
23 - PK-6 Open House (6:30 PM)  
24 - Faculty Inservice  
25 - 1st Day of School

## JANUARY

S	M	T	W	T	F	S
1	2	3	4	5	6	7
8	9	10	11	12	13	14
15	16	17	18	19	20	21
22	23	24	25	26	27	28
29	30	31				

S	M	T	W	T	F	S
			1	2	3	4
5	6	7	8	9	10	11
12	13	14	15	16	17	18
19	20	21	22	23	24	25
26	27	28				

## FEBRUARY

S	M	T	W	T	F	S
						1
2	3	4	5	6	7	8
9	10	11	12	13	14	15
16	17	18	19	20	21	22
23	24	25	26	27	28	29
30	31					

## MARCH

S	M	T	W	T	F	S
			1	2	3	4
5	6	7	8	9	10	11
12	13	14	15	16	17	18
19	20	21	22	23	24	25
26	27	28	29	30	31	

## APRIL

S	M	T	W	T	F	S
						1
2	3	4	5	6	7	8
9	10	11	12	13	14	15
16	17	18	19	20	21	22
23	24	25	26	27	28	29
30						

## MAY

S	M	T	W	T	F	S
	1	2	3	4	5	6
7	8	9	10	11	12	13
14	15	16	17	18	19	20
21	22	23	24	25	26	27
28	29	30	31			

S	M	T	W	T	F	S
				1	2	3
4	5	6	7	8	9	10
11	12	13	14	15	16	17
18	19	20	21	22	23	24
25	26	27	28	29	30	

September 5 - Labor Day - NO SCHOOL  
26 - Homecoming Coronation (7:30)  
30 - Homecoming FB vs. Sisseton

October 7 - Marching Band Festival  
10 - Native American Day - NO SCHOOL  
21 - End of 1st Quarter (40)  
27 - Parent/Teacher Conferences (1:30-8:30)  
28 - Faculty Inservice - NO SCHOOL

S	M	T	W	T	F	S
						1
2	3	4	5	6	7	8
9	10	11	12	13	14	15
16	17	18	19	20	21	22
23	24	25	26	27	28	29
30	31					

November 7 - MS/HS Fall Family Night  
11 - Veterans Day  
23-25 - Thanksgiving Break - NO SCHOOL

December 8 - MS/HS Christmas Concert (7:00)  
9 - Elementary Christmas Concert (2:00)  
21 - End of 1st Semester (39/79)

S	M	T	W	T	F	S
		1	2	3	4	5
6	7	8	9	10	11	12
13	14	15	16	17	18	19
20	21	22	23	24	25	26
27	28	29	30			

January 4 - School Resumes  
13 - Faculty Inservice - NO SCHOOL

February 9 - Parent/Teacher Conferences (1:30-8:30)  
10 - Faculty Inservice - NO SCHOOL  
20 - President's Day - NO SCHOOL

S	M	T	W	T	F	S
				1	2	3
4	5	6	7	8	9	10
11	12	13	14	15	16	17
18	19	20	21	22	23	24
25	26	27	28	29	30	31

March 10 - End of 3rd Quarter (45)  
16-17 - Spring Break - NO SCHOOL

April 14 - Good Friday - NO SCHOOL  
17 - Easter Monday - NO SCHOOL  
27 - FCCLA Style Show  
28 - FFA Banquet

Month	C	N	T
August	5	2	7
September	21	0	21
October	19	2	21
November	19	0	19
December	15	0	15
January	19	1	20
February	18	2	20
March	21	0	21
April	18	0	18
May	14	1	15
Totals	169	8	177

May 1 - Kiwanis Athletic Banquet  
2 - Elementary Spring Concert (7:00)  
4 - MS/HS Spring Concert (7:00)  
18 - End of 2nd Semester (45/90)  
19 - Faculty Inservice - NO SCHOOL  
21 - SENIOR GRADUATION (2:00)

**\*\*All make-up days will be added on to the end of the school year.**

Faculty In-Service	Blue
No School	Red
Important Dates	Yellow
P/T Conferences	Orange
End of Quarter	Green

### Frederick Town December Meeting Minutes

Town of Frederick  
December Minutes  
Chairman Scott Campbell called the meeting to order at 7 PM in the Frederick Community Center. Council members Scott Campbell, Richard Osborn, Thomas Meyer and Diane Bruns, Finance Officer were present with Utility Manager Richard Bakeberg, Don (Sam) Brummond, and Gary Schlosser.

The November 2, 2015 minutes were reviewed and approved with motion by RO/TM. Motion Carried. The Financial Report was presented and reviewed by the board.

Council member TM made motion with 2nd by RO to approve. Motion Carried.

Approval of the Accounts Payable for the month of December was reviewed with a motion made and seconded by TM/RO. Motion Carried. Don Brummond of Sam's Way Trucking presented a bill for gravel hauled. The bill was paid with a motion by TM/RO and begins January's accounts payable. Motion Carried.

ACCOUNTS PAYABLE:  
A&B Business Solutions supplies W/G/S \$369.62; Alpha Circle Upkeep share Cemetery \$1714.84; R Bakeberg UT Mgr W/G/S \$294.34; Black Mountain

Software Annual Maintenance W/G/S \$1308; Crawford & Equip Snowplow parts St \$994.80; DENR Annual Fees Lagoon \$250; D Bruns maintenance CC \$133.91; Bruns FO Fin Off \$1000.03; Dennis Durheim gravel St Repairs \$320.22; Farmers Union Oil diesel, fuel oil Gen/I EBL \$323.05; FDC Econ Dev ED \$1500; GDI legals Genl \$41.32; JVC phones, services, Internets Gen/I/EBL/Wtr/FO \$284.62; M Cox Librarian EBL \$471.93; MDU elect Fire/Wtrwr/SPark/BPark/Wtr/CC/FO/Lagoon/St/EBL \$1151.44; Menards Supplies St \$77.53; RS Campbell, Chairman Gen'l \$46.18; R Osborn, Brd Mmbr \$23.09; SD Dept of Health lab Gen'l \$104; SD Dept of Rev ST Garbage \$75.40; SD Govt FO Assoc membership dues FO \$40; SDML Annual dues Gen'l \$169.21; USPS stamps Wtr/G/Swr \$147; USDA-RP AP Water Loan \$475; WEB Water 666,900 gallons Wtr \$2262.09. Total A/P \$13,577.62.

OLD BUSINESS:  
Rich Bakeberg gave the Utility Report. He is going to be burning the city dump. No discharging is being done at the Lagoon.

It was noted the Dallenbach trailer has been sold and the past utility bill has been paid.

A motion was made by SC/TM to shut off water to 3 residents, all over \$200 due. Motion Carried.

Frederick Forward- may be passing on putting up Christmas decorations due to the quality of existing ones.

Historical Society-  
Emma Burnham library- Furnace is repaired, still waiting on new water heater and roof getting done. Scott is checking on insurance for building. A board member is going to ask Prairie Builders about replacing the wrapped floor with plywood. Open House is December 11, 2015.

Frederick Dev Corp- OTHER OLD BUSINESS:

A letter will be sent about the rubble pile next to the FB field. The pile is a liability to the city.

Richard Osborn and wife Sharon are going to clean the cement out of the monument in Simmons Park and paint the inside. After cleaning it up they will replace the artifacts that have been at the Historical Society for safe keeping.

Chairman Campbell is still waiting on an example ordinance to reclassify the city tax for a local resident. He will contact the city's attorney to get an Ordinance drawn up and passed during the 1st quarter of 2016.

Sanding was done on Main and 3rd Ave during the last snow fall. Hopefully it helped our residents get around a little easier.

NEW BUSINESS:

The 2nd Reading of Ordinance #197 Sewer Increase was held. After final review from the board the Ordinance was passed with a motion by TM/RO. The sewer rate will be \$22 beginning January 1, 2016. Roll call vote: Campbell- aye, Meyer- aye; Osborn- aye. Motion Carried.

It was decided to move up with technology and possibly purchase new Trimble Reader. Bakeberg has a quote from Meter and Technology Solutions and a representative may come to explain the new system for reading and billing water usage.

Frederick joined only the FO Association of the SDML Affiliate memberships.

The joint meeting with the Brown County Planning Commission is Tuesday, December 15, 2015 in the Public Safety Building at 7 PM. They will be approving or not the Preliminary and Final Plat for Highway property to the N of Frederick. They will also be granting a Variance to lot size and a Variance to Lot Frontage Width on the same property. All board members are to be in attendance.

CORRESPONDENCE:

The letter for Environmental Fees was reviewed; the 2016 Annual Report Workshop for FO and board members is January 28, 2016 which FO Bruns will attend; US Dept of Interior/National Wildlife Federation sent letter on the transmission line proposed to cross Brown County; Urban Forestry Comprehensive Challenge Grant Funds are available; Join International League of Cities, no.

Will stop payment on 2014 check and reissue for \$32.22.

No employee bonuses.

Council member Osborn made a motion to adjourn the meeting at 7:50PM, Council member Meyer seconded. Motion Carried.

Diane Bruns  
Frederick Finance Officer  
Published once at the total approximate cost of \$45.37. (11757)

**Parts • Sales • Service**

**ABERDEEN - 800-843-1865**  
4935 6th Ave. SE  
Aberdeen, SD 57401

**REDFIELD - 800-247-4650**  
17440 - US HWY 281  
Redfield, SD 57469

**WEBSTER - 800-658-2252**  
901 W. Highway 12  
Webster, SD 57274

**RDO EQUIPMENT CO.**

**Stocking stuffing ideas that will make dad happy!**

**S & S Lumber**

**North Groton**

# October Students of the Month

The student council is sponsoring Student of the Month. Each month the faculty select students who show outstanding academic achievement. These students receive certificates and have year-end lunch with the principal.

**Senior Lily Cutler's** parents are James and Lisa Cutler from Claremont. Greyson Cutler is her brother.

Lily is involved in yearbook, oral interp, Destination Imagination, debate, youth group and was the cross country student manager. Her accomplishments are honor roll, student of the month, receiving a superior and first superior rating in oral interp, qualifying for state in oral interp, qualifying for DI Global Finals, being on the National Honor Society and earning the President's Service Award.

Lily's interests are reading, studying, sleeping, watching Netflix and hanging out with family and friends. Chemistry is her favorite subject and her role models are her parents. Lily plans to attend South Dakota School of Mines and Technology and major in chemical engineering.

**Junior Erin Smith** is the daughter of Dr. Steve and Carol Smith of Groton. Her siblings are Samuel, Marah, Luke, AnneMarie and Isaac. Erin's activities are show choir, all-school play, choir, band, Jazz band, oral interpretation, FCCLA, piano and running cross country. Her accomplishments are earning superiors for instrumental and vocal solos, advancing to state oral interpretation and placing at cross country meets.

Erin's interests are music, reading, spending time with friends and family and Sci-fi. English is her favorite subject and her role model is her dad. Erin plans to teach high school English.

**Sophomore Jenifer Fjelstad** is the daughter of Clint and Tara Fjelstad, Groton. Her activities are show choir, dance team, Destination Imagination, oral interp, cross country, St. Paul's youth group, 2TY:12, band and choir. Jenifer's accomplishments are 4.0 honor roll, making state oral interp, going to Global DI Finals and earning an superior rating plus in oral interp.

Jenifer's interests are dance, time with friends and family, singing and reading. Chemistry is her favorite subject and her parents are her role models. She plans to attend college after graduation.

**Freshman Tylan Glover** is the son of Burt and Angela Glover, Groton. Tady Glover is his sister, who is in the eighth grade. Tylan's activities are being in honor band, All-State Choir, Middle School All-State Band for two years and earning MathCounts team awards.

Tylan's interests are fine arts, such as band, choir and school play) and sports. Math is his favorite subject and Mr. Cody Swanson is his role model. After graduation he plans to go into psychology or some kind of fine arts major.

**Ashley Flihs**, eighth grade, is the daughter of Kristie and Jarod Flihs, Groton. Her siblings are Megan and Brevin. Ashley's activities include dance, volleyball, keeping basketball stats, being in the Car-



**Back - Tylan Glover (grade 9), Jenifer Fjelstad (grade 10), Erin Smith (grade 11), Lily Cutler (grade 12)**  
**Front - Ashley Flihs (grade 8), Erin Unzen (grade 7), Seth Johnson (grade 6)**

nival of Silver Skates, in band and choir. She had earned MathCounts awards. Ashley is interested in dance and cooking and FACS is her favorite subject. Her mom is her role model and she plans to be a photographer and a baker.

**Erin Unzen**, seventh grade, is the daughter of Jake and Tiffany Unzen, Groton. Her siblings are Nathan, Megan and Haley. Erin's activities are basketball, volleyball, band, golf, church youth group and ice skating. Her accomplishments are placing in MathCounts, winning poetry contest, honor roll and being a previous student of the month. She is interested in baking, playing volleyball and hanging out with friends. English is her favorite subject and her mom is her role model. Erin's future plans are undecided.

**Seth Johnson**, sixth grade, is the son of Greg and Mary Johnson, Bristol. His siblings are Cole, Scott and Angie. He is involved in basketball and baseball and his interests are hunting, snowmobiling and tubing. Seth's accomplishments are youth football tournament champions and being on the honor roll. PE is his favorite subject and Luke Bryan is his role model.

**Westport Town Wastewater, Storm Water Project Notice**  
 NOTICE OF PUBLIC HEARING for the Westport Wastewater and Storm Water Improvement Project

The Town of Westport is seeking up to \$400,000 of funding from the Board of Water and Natural Resources for improvements to the wastewater treatment and storm water system. These improvements include placing rip-rap at the lagoon and replacing the lift station. The project will also add in some additional storm water system. The funds could be either a grant from the state Consolidated Water Facilities Construction Program or a loan from the Clean

Water State Revolving Fund (SRF) Program. The Clean Water SRF loan terms are 3.25% for 30 years, and the Board of Water and Natural Resources may forgive all or a portion of loan principal. The amount, source of funds, and terms will be determined by the Board of Water and Natural Resources when the application is presented at a scheduled board meeting. The purpose of the public hearing is to discuss the proposed project, the proposed financing, and the source of repayment for the loan. The public is invited to attend and comment on the project.

The public hearing will be held at City Hall on December 29, 2015 at 7:00pm.

Published once at the total approximate cost of \$13.24. (11756)



## Honor Band

These Groton Area students participated in the Honor Band.

**Back Row (left to right): Maggie Simon, Tylan Glover, Garrett Stene, Jaden Oliver, Mrs. Yeigh**

**Front Row (Left to right): Ashley Garduno, Emily Thompson, Kylie Kassube**

**Not pictured is Josie Doeden due to illness**

**S & S Lumber/Hardware Hank of Groton will be closing at noon on Wednesday, Dec. 16th, for inventory and will reopen at normal hours on Thursday.**

Get the **Coverage** You Need

Medicare Supplement Made Simple

Sign up now, no health questions asked.

Call 1-877-503-9725 and ask for your local agent to compare rates.

Network restrictions apply with Select plans. Neither Avera Health Plans nor its agents are connected with Medicare or state or federal government. This is a solicitation and you will talk to an Avera Health Plans sales associate but are under no obligation to purchase.

**Avera** Health Plans

# Groton girls open season with win over Ipswich

The Groton Area girls opened its basketball season with a 62-46 win over Ipswich in a game played Thursday night in Groton.

Groton Area led at the quarterstops at 10-9, 26-21 and 45-35.

"We'll take the win," said Coach Shaun Wanner. "We scored a lot of points, but we need to rebound better. We gave Ipswich too many second chances. There are a few areas that we need to work on, but overall, the girls played well."

Katie Koehler led Groton Area with 24 points followed by Harleigh Stange with 12, Carly Wheeting 10, Audrey Wanner eight and Jessica Bjerke and Emily Locke each had four points.

Groton Area had 30 rebounds with Emily Locke and Wheeting each having six, 11 assists with Stange having three, two steals - one each by Koehler and Wheeting, Koehler had one block and the team had 21 fouls with Bjerke fouling out. Groton Area made 46 percent of its field goals and nine of 15 free throws. Groton Area made 11 three-point shots - six by Koehler, four by Stange and one by Wanner.

Ipswich was led in scoring by Kamryn Heinz with 20 points followed by Elizabeth Grabowske with 16 and adding two points each were Autumn Pitz, Kayler Braun, Allison Sorenson, Aleah Steger and Abby Grabowske.

Ipswich had 28 rebounds, 14 turnovers, 16 tteam fouls, five steals, seven assists and made 36 percent of its field goals while making 16 of 28 free throws.

Groton Area won the junior varsity game, 32-33. Scoring for Groton Area were Taylor Holm with 11, Portia Kettering seven, Jenny Doeden and Madison Sippel each with four and adding two points apiece were Miranda Hanson, Alex Stange, Sam Menzia and Jodi Hinman. Allison Severson led Ipswich with 10 points and Aleah Steger added eight.



Harleigh Stange brings the ball up court for the Tigers.



Katie Koehler goes up for the shot and gives Groton Area 45-32 lead in the third quarter.



Audrey Wanner grabs the rebound before it reached the hands of this Ipswich player.

## Statewide Classifieds

### EMPLOYMENT

CUSTER CLINIC and Custer Regional Senior Care are accepting applications for full and part-time Licensed Medical Assistants, LPNs and RNs to join our teams in the beautiful southern Black Hills. Excellent benefits and competitive salary. Contact Human Resources at (605) 673-9418 for more information or log onto [www.regional-health.com](http://www.regional-health.com) to apply. EEOC/AA.

SPECIAL EDUCATION TEACHER grades 5-6, Custer Elementary School starting 1/4/16, 4-day week; \$31,500 base; Custer School District, 527 Montgomery St., Custer, SD 57730, 605.673.3154 [csd.k12.sd.us](mailto:csd.k12.sd.us).

60 YEAR OLD financially strong family owned chain with 8 stores in Colorado, Nebraska and South Dakota. We have an opening for a meat department manager. We offer a competitive starting salary, quarterly bonus, health insurance, and 401k with a match. You want to be part of a great family chain of stores, please e-mail me your resume to: [msteck58@gmail.com](mailto:msteck58@gmail.com) or mail it to Personnel Manager, PO Box 600630, San Diego, CA 92160-0630.

FACILITY MAINTENANCE SUPERINTENDENT – Spearfish. Manages facility maintenance operations for buildings/grounds owned by City. EOE. Position description and application process on our website [www.cityofspearfish.com](http://www.cityofspearfish.com).

HELP WANTED: Full time farm/ranch manager position available in Presho, SD. All inquiries confidential, top pay for qualified applicants. Contact Dustin Smith 605-280-4641.

### MISCELLANEOUS

MEET SINGLES RIGHT NOW! No paid operators, just real people like you. Browse greetings, exchange messages and connect live. Try it free. Call now: 1-800-958-7963.

### NOTICES

ADVERTISE IN NEWSPAPERS state-wide for only \$150.00. Put the South Dakota Statewide Classified Network to work for you today! (25 words for \$150. Each additional word \$5.) Call this newspaper at 397-6397 for details.

**Ken's SUPER FAIR FOODS**  
FOOD FAIR EXPRESS  
www.kenssuperfair.com  
Aberdeen • Groton • Clark • Ipswich • Eureka • Britton  
View Our Weekly Flyer on the American News Mobile App!  
All Ken's Locations Are Now Accepting American Express Cards

<p><b>USDA Choice Whole Boneless New York Strip</b> Per Lb. <b>\$6.49</b> Cut, Wrapped &amp; Frozen For Free</p>	<p><b>John Morrell Whole or 1/2 SBO Ham</b> Per Lb. <b>\$1.98</b></p>	<p><b>Ken's BIG VIP DEAL</b> <b>Premium Gold Pineapple</b> Each <b>\$2.49</b></p>
<p><b>Coke, Diet Coke or Coke Zero</b> 12 Pack 12 Oz. Cans or 8 Pack 12 Oz. Bottles <b>3 for \$9.99</b></p>	<p><b>Pepsi, Diet Pepsi or Mt. Dew</b> 12 Pack 12 Oz. Cans <b>3 for \$9.99</b></p>	<p><b>Chic Biscuits</b> <b>Wheat Thins</b> <b>\$1.99</b></p>
<p><b>A&amp;W, 7UP, Sunkist or Squirt</b> 6 Pack .5 Liter Bottles <b>3 for \$5</b></p>	<p><b>Festive Bone In Turkey Breast</b> Per Lb. <b>\$1.49</b></p>	<p><b>Nabisco Assorted Snack Crackers</b> 3.5-9.1 Oz. <b>\$2.99</b></p>
<p><b>Butter Kernel Corn, Green Beans or Sweet Peas</b> 14.5-15 Oz. Cans <b>2 for \$1</b></p>	<p><b>Charmin Basic Bathroom Tissue</b> 12 Double Roll Pkg. <b>\$4.99</b></p>	<p><b>Ocean Spray Cocktail Blended Drinks</b> 64 Oz. Jug <b>\$2.49</b></p>
<p><b>Pillsbury Cake Mix</b> 15.25 Oz. Box <b>99¢</b></p>	<p><b>Nestle Toll House Morsels</b> 10-12 Oz. Bags <b>2 for \$5</b></p>	<p><b>Betty Crocker Assorted Specialty Potatoes</b> 3.7-5.1 Oz. Boxes <b>10 for \$10</b></p>
<p><b>Pillsbury RTS Frosting</b> 1.4 Oz. Tub <b>\$1.49</b></p>	<p><b>Kraft Velveeta</b> 2 Lb. Leaf <b>\$5.88</b> With 70¢ OFF Coupon on Page 4</p>	<p><b>Tombstone Original Pizza</b> 12 Inch <b>\$3.99</b> Each</p>
<p><b>Bud, Bud LT, Select 55</b> 15 Pk. Cans and Bottles <b>\$14.99</b></p>	<p><b>Windsor</b> 1.75 Ltr. <b>\$14.99</b> Buy 6 get \$20 Mail in Rebate Your Final Cost Per Bottle <b>\$11.66</b></p>	

**Groton Chamber Holiday Boxes are out & about in Groton!**

This Week (thru 12/18) – Professional Management Supply  
\*\*\$25 Chamber Bucks OR Mystery Gift\*\*

Next Week (thru 12/23) – Olde Bank Floral 'N More  
\*\*\$25 Chamber Bucks or a Fresh Floral Christmas Bouquet

Stop by each participating business and register for \$25 Groton Chamber Bucks – or a prize supplied by the business.

**GROTON Chamber Of Commerce**

**Merry Christmas**